

M8100 Synchroscope

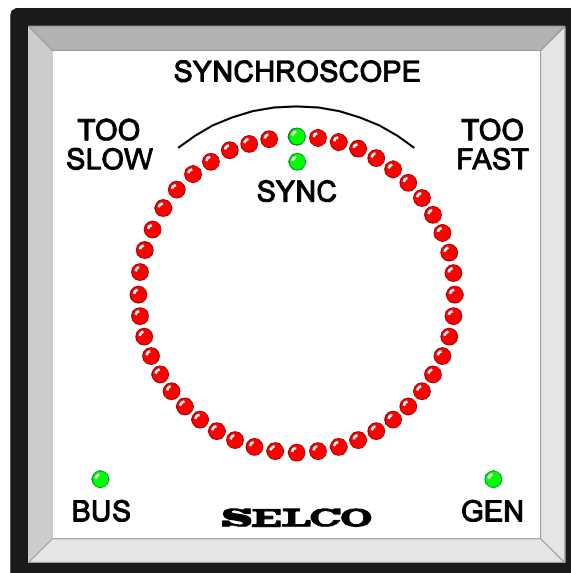

User Manual

SELCO A/S
Betonvej 10 - DK-4000 Roskilde
Denmark
Phone: 45 7026 1122 - Fax: 45 7026 2522
e-mail: selco.dk@selco.com
Web site: www.selco.com

Table of contents

1	Preface.....	3
2	Function	3
3	Connections.....	3
4	Adjustments	4
4.1	Check synchronizer relay.....	4
4.2	Dead bus closure	5
4.2.1	Voltage Offset.....	5
4.2.2	Dead busbar delay time.....	5
5	Specifications	6
6	Type Selection Table	7

1 Preface

This manual describes the M8100 Synchroscope with built-in check synchronizer relay and dead bus closure function.

2 Function

The M8100 Synchroscope provides illuminated indication of the actual phase difference between generator voltage and bus voltage. If the vector and the light spot turn clockwise, the generator frequency is too high and must be reduced. The light spot turning anti clockwise indicates a lower generator frequency, and consequently it must be increased.

In case the generator and busbar voltage and frequency and phase angle are within acceptable limits, the built-in check synchronizer relay will activate. The limits of above parameters can be adjusted by a potentiometer on the rear side of the unit.

For clearing of blackout situations the M8100 Synchroscope can be set up to connect a live generator to a dead busbar (dead busbar closure function). When enabled, the M8100 Synchroscope will give a close command to the generator breaker in case it detects that the busbar voltage is below dead busbar voltage offset limit and the generator has reached at least 80% of its nominal voltage. The busbar must be dead during the entire dead busbar delay time (this time delay is also adjustable). The purpose of the dead busbar voltage offset is to give room for possible noise on the busbar voltage input of M8100 Synchroscope.

Warning: As this function could lead to short circuits (e.g. when more than one generator are connecting to a dead busbar at the same time, this function should be treated carefully.

3 Connections

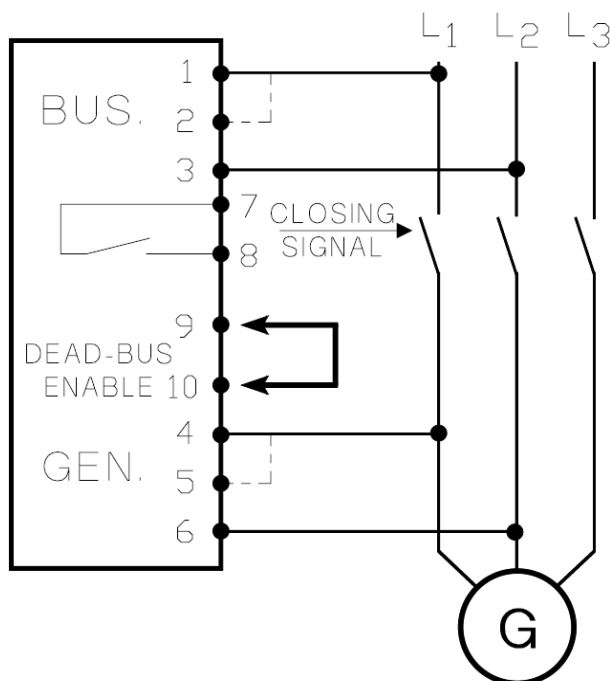

Before commissioning, make sure that the phase sequences of generator and busbar connections are correct.

4 Adjustments

On the rear side of the unit are a number of potentiometers and DIP switches for programming of the unit:

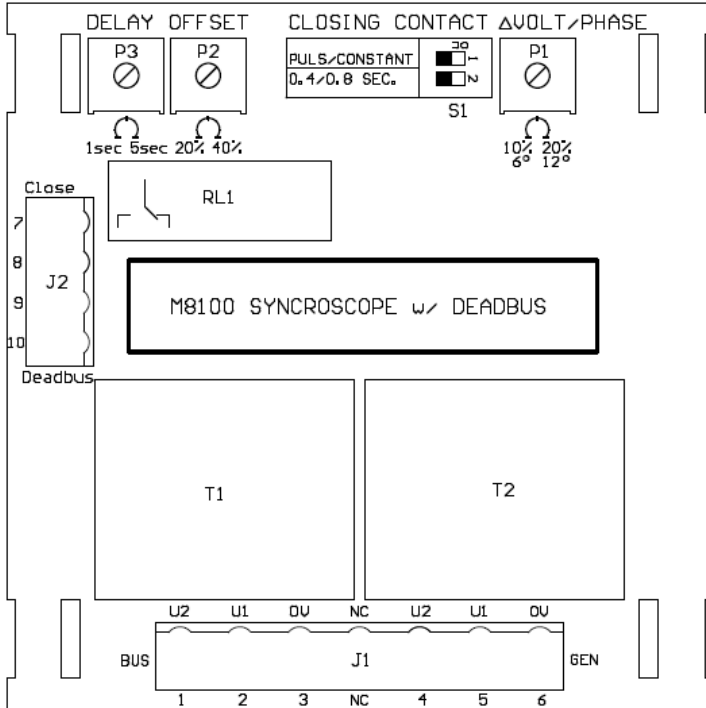

4.1 Check synchronizer relay

On DIP switch S1 pin 1 the check synchronizer relay can be programmed to offer a constant closing signal that remains activated as long as voltage-, frequency-, and phase difference between generator and busbar voltage are within limits for automatic closure, or a pulse signal of 0,4 or 0,8s.

S1, pin1 OFF, pulse signal
 S1, pin1 ON, constant signal

In case S1, pin1 is in OFF position, S1, pin2 can be used for programming the length of the closing pulse:

S1, pin 2 OFF, closing pulse of 0,4s
 S1, pin 2 ON, closing pulse of 0,8s

On potentiometer P1 the acceptable limits for voltage-, frequency- and phase deviation can be adjusted. It is a combined setting on one potentiometer. Narrowest limits are adjusted by turning P1 counter clockwise until end position. Then the limits are as follows:

$$\Delta U = 10\%$$

$$\Delta f = 0,15\text{Hz}$$

$$\Delta\phi = 6^\circ$$

The highest tolerance is adjusted by turning the potentiometer P1 clockwise until end position. Then the limits are as follows:

$$\Delta U = 20\%$$

$$\Delta f = 0,3\text{Hz}$$

$$\Delta\varphi = 12^\circ$$

4.2 Dead bus closure

This function enables the built-in check synchronizer relay to close the circuit breaker even though there is no voltage on the busbar. The generator voltage must be at least at 80% of the nominal voltage before the dead bus closure can activate.

For activating the dead bus closure, terminals 9 and 10 must be bridged.

4.2.1 Voltage Offset

The purpose of the dead busbar voltage offset is to give room for possible noise on the busbar voltage input of M8100 Synchroscope.

The M8100 Synchroscope considers the busbar to be dead in case the busbar voltage is below the dead busbar voltage offset. This offset can be adjusted by potentiometer P2. The range is between 20% of nominal voltage to 40% of nominal voltage.

Turning P2 counter clockwise until end position means 20%.

Turning P2 clockwise until end position means 40%.

4.2.2 Dead busbar delay time

The dead bus closure facility will only close the breaker to the dead busbar in case the busbar voltage has been below the voltage offset limit during the entire time delay. This time delay can be adjusted by potentiometer P3.

Turning P3 counter clockwise to end position: delay = 1s

Turning P3 clockwise to end position: delay = 5s

5 Specifications

Max. Voltage	660V
Voltage range	70 - 110%
Consumption	2x 3VA max.
Frequency range	35 - 70Hz
Pull in / drop out diff. frequency	±9Hz
Operating temperature	-20°C to +70°C
EMC	CE according to EN50081-1, EN50082-1, EN50081-2, EN50082-2
Approvals	Certified by major classification societies
Burn-in	50 hours before final test
Enclosure material	Flame retardant
Weight	0.7kg
Dimensions	96 x 96 x 80mm (H x W x D)
Panel cut out	92 x 92mm (H x W)
Check sync. relay	
Voltage difference	10 - 20%
Frequency difference	0.15 - 0.3Hz Combined setting
Phase difference	6 - 12°
Dead bus delay	1s – 5s
Dead bus voltage offset	20% - 40%
Min. generator voltage for DB closure	80% of nominal voltage
Contact rating	AC: 250V, 1.2A, 125VA DC: 30V, 1A, 30W

The specifications are subject to change without notice.

6 Type Selection Table

Type	Terminals		Function
	1-3	2-3	
	4-6	5-6	
M8100.0050	450V	400V	With check synchronizer relay
M8100.0060	230V		With check synchronizer relay
M8100.0070	480V	415V	With check synchronizer relay
M8100.0080	110V	100V	With check synchronizer relay

Other voltages on request.