

2301A Systems for Split Shaft Gas Turbines and Engine/Torque Converter Applications

Application Note 50536

WARNING—DANGER OF DEATH OR PERSONAL INJURY



WARNING—FOLLOW INSTRUCTIONS

Read this entire manual and all other publications pertaining to the work to be performed before installing, operating, or servicing this equipment. Practice all plant and safety instructions and precautions. Failure to follow instructions can cause personal injury and/or property damage.



WARNING—OUT-OF-DATE PUBLICATION

This publication may have been revised or updated since this copy was produced. To verify that you have the latest revision, be sure to check the Woodward website:

www.woodward.com/pubs/current.pdf

The revision level is shown at the bottom of the front cover after the publication number. The latest version of most publications is available at:

www.woodward.com/publications

If your publication is not there, please contact your customer service representative to get the latest copy.



WARNING—OVERSPEED PROTECTION

The engine, turbine, or other type of prime mover should be equipped with an overspeed shutdown device to protect against runaway or damage to the prime mover with possible personal injury, loss of life, or property damage.

The overspeed shutdown device must be totally independent of the prime mover control system. An overtemperature or overpressure shutdown device may also be needed for safety, as appropriate.



WARNING—PROPER USE

Any unauthorized modifications to or use of this equipment outside its specified mechanical, electrical, or other operating limits may cause personal injury and/or property damage, including damage to the equipment. Any such unauthorized modifications: (i) constitute "misuse" and/or "negligence" within the meaning of the product warranty thereby excluding warranty coverage for any resulting damage, and (ii) invalidate product certifications or listings.

CAUTION—POSSIBLE DAMAGE TO EQUIPMENT OR PROPERTY



CAUTION—BATTERY CHARGING

To prevent damage to a control system that uses an alternator or battery-charging device, make sure the charging device is turned off before disconnecting the battery from the system.



CAUTION—ELECTROSTATIC DISCHARGE

Electronic controls contain static-sensitive parts. Observe the following precautions to prevent damage to these parts.

- Discharge body static before handling the control (with power to the control turned off, contact a grounded surface and maintain contact while handling the control).
- Avoid all plastic, vinyl, and Styrofoam (except antistatic versions) around printed circuit boards.
- Do not touch the components or conductors on a printed circuit board with your hands or with conductive devices.

IMPORTANT DEFINITIONS

- A **WARNING** indicates a potentially hazardous situation which, if not avoided, could result in death or serious injury.
- A **CAUTION** indicates a potentially hazardous situation which, if not avoided, could result in damage to equipment or property.
- A **NOTE** provides other helpful information that does not fall under the warning or caution categories.

Woodward Governor Company reserves the right to update any portion of this publication at any time. Information provided by Woodward Governor Company is believed to be correct and reliable. However, no responsibility is assumed by Woodward Governor Company unless otherwise expressly undertaken.

© Woodward 1990
All Rights Reserved

Contents

ELECTROSTATIC DISCHARGE AWARENESS	II
CHAPTER 1. GENERAL INFORMATION.....	1
Introduction.....	1
Selection of Controls	2
Power Generation.....	2
Reference Publications	2
CHAPTER 2. INSTALLATION.....	4
Introduction.....	4
Unpacking.....	4
Selection of Speed Range.....	4
Location Considerations.....	5
Electrical Connections.....	5
Shielded Wiring	5
Installation of Controls.....	6
Power Supply.....	6
External Adjustments.....	7
Speed Trim	7
Droop Potentiometer	7
Switch Options.....	7
Minimum Fuel Contact.....	7
Failed Speed Signal Override.....	7
Idle/Rated Ramp Contact	8
Acceleration Ramp	8
Actuator Output.....	8
Speed Sensor	9
Frequency and Phase Matching with an SPM-A Synchronizer.....	9
Auxiliary Input	9
Installation Check-Out Procedure	9
Dynamic Adjustment.....	10

Illustrations and Tables

Figure 1-1. Block Diagram of Speed Control Application.....	3
Figure 1-2. Block Diagram of Load Sharing and Speed Control Application	3
Figure 2-1. Speed Range Switch	4
Figure 2-2. Preparation of Shielded Cables	6
Figure 2-3. Plant Wiring Diagram, Split Shaft Speed Control	11
Figure 2-4. Plant Wiring Diagram, Split Shaft Load Sharing and Speed Control.....	12

Electrostatic Discharge Awareness

All electronic equipment is static-sensitive, some components more than others. To protect these components from static damage, you must take special precautions to minimize or eliminate electrostatic discharges.

Follow these precautions when working with or near the control.

1. Before doing maintenance on the electronic control, discharge the static electricity on your body to ground by touching and holding a grounded metal object (pipes, cabinets, equipment, etc.).
2. Avoid the build-up of static electricity on your body by not wearing clothing made of synthetic materials. Wear cotton or cotton-blend materials as much as possible because these do not store static electric charges as much as synthetics.
3. Keep plastic, vinyl, and Styrofoam materials (such as plastic or Styrofoam cups, cup holders, cigarette packages, cellophane wrappers, vinyl books or folders, plastic bottles, and plastic ash trays) away from the control, the modules, and the work area as much as possible.
4. Do not remove the printed circuit board (PCB) from the control cabinet unless absolutely necessary. If you must remove the PCB from the control cabinet, follow these precautions:
 - Do not touch any part of the PCB except the edges.
 - Do not touch the electrical conductors, the connectors, or the components with conductive devices or with your hands.
 - When replacing a PCB, keep the new PCB in the plastic antistatic protective bag it comes in until you are ready to install it. Immediately after removing the old PCB from the control cabinet, place it in the antistatic protective bag.



CAUTION—ELECTROSTATIC DISCHARGE

To prevent damage to electronic components caused by improper handling, read and observe the precautions in Woodward manual 82715, *Guide for Handling and Protection of Electronic Controls, Printed Circuit Boards, and Modules*.

Chapter 1.

General Information

Introduction

Special 2301A controls are used to provide load sharing and speed control for installations with engines driving loads isolated through torque converters or for split shaft gas turbines.

These systems use magnetic pickups (MPUs) on both the engine or gas compressor side of the unit and the power turbine or driven load (tailshaft) side. Connecting the two speed controls in series assures that the actuator, which controls the flow of fuel, will take the position providing the minimum amount of fuel needed to maintain the desired speed on the isolated load.

In each case, the speed of the engine or gas generator is controlled so as not to exceed the rated speed limit.

Many of these applications cannot be adequately controlled by a single control.

If only the speed of the power unit is monitored, it cannot adequately respond to load changes, and instability can be expected. Controlling only the speed of the isolated load presents dangers of overspeed by the prime mover should the coupling fail, and can also make starting extremely difficult.

Installations producing an electrical power output may use a 2301A speed and load control and a 2301A speed control connected in series.

Using a series connection between the two speed controls provides a low-signal-select feature at the actuator. Likewise the primary control is the speed control on the driven load (N2). The speed control on the engine or gas generator functions as a limiter, preventing the power unit from calling for excessive speed. This control provides speed control should the flexible coupling open, allowing the driven load or the power turbine to go grossly underspeed.

The connection of the two controls to a single actuator does not eliminate any of the features included within the control. Each control offers speed trim, remote input from automatic equipment, droop or isochronous control, failed speed signal override, idle and rated speeds, and auxiliary input for use by a load sensor or temperature sensor.

Except for a circuitry to allow series installation, the controls used are identical to those used on single control applications.

Selection of Controls

Identical 2301A speed controls, Woodward part number 9905-181, are used for control of mechanical loads for either a split shaft gas turbine or a torque converter application.

Speed ranges on the units are set by internal switches. The speeds must be set to accommodate the desired frequency to be sensed by the particular magnetic pickup. The frequency is determined by multiplying the desired maximum rpm of the sensed gear by the number of teeth and dividing the total by 60.

Although the desired rpm of both the engine and tailshaft are usually nearly identical, it is unusual if the gears being used to sense speed are the same.

Power Generation

Power generation applications are normally restricted to gas turbines. Because of the wide assortment of auxiliary features available with the 2301A Load Sharing and Speed controls, this is the normal selection for control of the N2 power turbine driving an electrical generator. The N1 gas turbine or compressor side of the unit is then controlled with the 2301A speed control. A 9905-181 speed control is used for the N1 gas turbine and a 9905-182 is used for the N2 power turbine.

The use of a load sharing and speed control 9905-182 allows generator load sensing, automatic synchronizing, isochronous load sharing, automatic generator loading, and other types of power generation control.

Woodward temperature limiting may be used with either the speed control or the load sharing and speed control.

Reference Publications

The 2301A Speed Control manual (82020) or the 2301A Load Sharing and Speed Control manual (82389) should be used for dynamic adjustment, trouble shooting and for additional information on the individual controls.

Outline drawings of the controls and block diagrams explaining in more detail how the control works are provided in these manuals.

Magnetic pickup installation is explained in manual 82510.

The 2301A controls output a 20 to 160 mA control signal. The fuel control actuator on the engine or turbine must accept this operating signal.

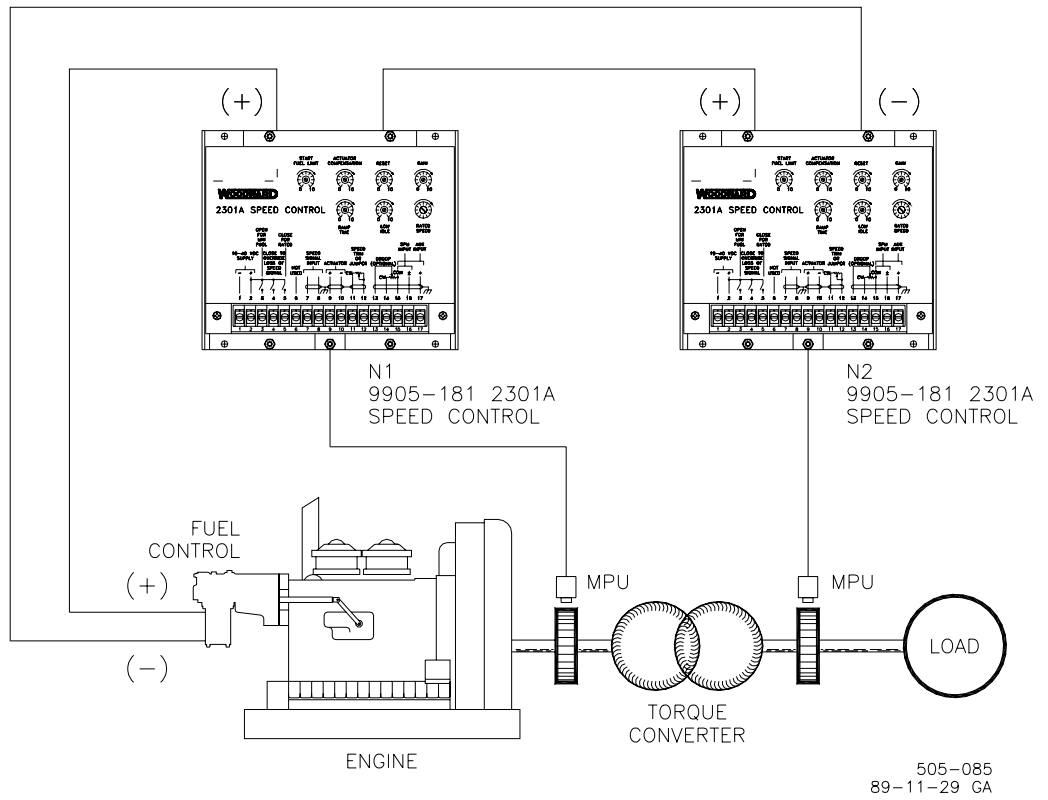

Figure 1-1. Block Diagram of Speed Control Application

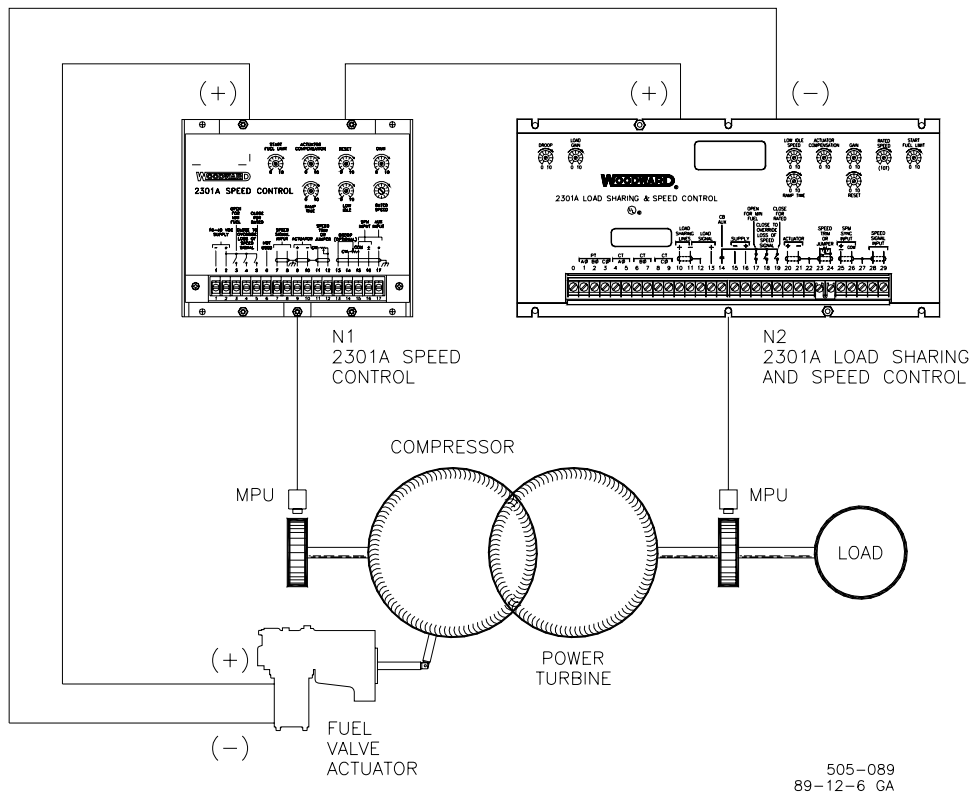

Figure 1-2. Block Diagram of Load Sharing and Speed Control Application

Chapter 2. Installation

Introduction

This chapter contains general installation instructions for 2301A split shaft or tailshaft controls. Power requirements, environmental precautions, and location considerations are included to determine the best location for the controls. Additional information includes unpacking instructions, electrical connections, and an installation check-out procedure.

Unpacking

Before handling the control, read the "Electrostatic Discharge Awareness" precautions on page ii. Be careful when unpacking the electronic control. Check the control for signs of damage such as bent or dented panels, scratches, and loose or broken parts. Notify the shipper of any damage.

Selection of Speed Range

A 4-pole mini-switch is located on the lower left quarter of the printed circuit board. This switch sets the controlling speed range as sensed by the MPU. The speeds are related to the MPU frequency, which is proportional to engine rpm. The control is shipped with Switch 3 on for 2000 to 6000 Hz. Switch 1 provides 500 to 1500 Hz, Switch 2 provides 1000 to 3000 Hz, and Switch 4 provides 4000 to 12000 Hz. Turn on only one switch to match the control to the MPU frequency.

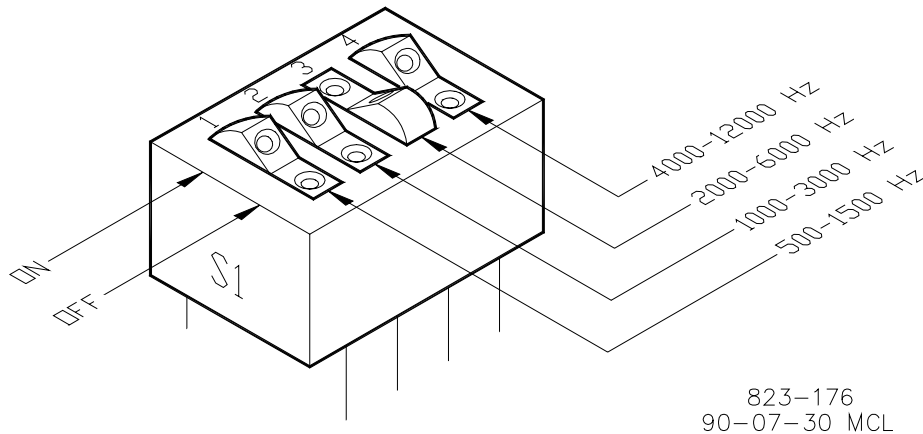

SWITCH S1

Figure 2-1. Speed Range Switch

Location Considerations

Consider these requirements when selecting the mounting location:

- Adequate ventilation for cooling
- Space for servicing and repair
- Protection from direct exposure to water or to a condensation-prone environment
- Protection from high-voltage or high-current devices, or devices which produce electromagnetic interference
- Protection from excessive vibration
- An ambient operating temperature range of -40 to $+85$ °C (-40 to $+185$ °F).



CAUTION—MOUNTING

Do not mount the control on the engine.

Electrical Connections

External wiring connections and shielding requirements for a typical control installation are shown in the plant wiring diagram, Figure 2-3 or 2-4. These wiring connections and shielding requirements are explained in the rest of this chapter.

Shielded Wiring

All shielded cable must be twisted-conductor pairs. Do not attempt to tin (solder) the braided shield. All signal lines should be shielded to prevent picking up stray signals from adjacent equipment. Connect the shields to the grounding lug on the chassis plate below terminal 9. Keep grounding connections under 15 cm (6 inches) in length. A solid ground connection must be made from "earth" or ground to the grounding lug to provide proper chassis grounding. Refer to local wiring codes for proper grounding methods.

Wire exposed beyond the shield should be as short as possible, not exceeding 15 cm (6 inches). The other end of the shields must be left open and insulated from any other conductor. Do not run shielded signal wires with other wires carrying large currents. See Application Note 50532, *EMI Control for Electronic Governing Systems*, for more information.

Where shielded cable is required, cut the cable to the desired length and prepare the cable as instructed below and shown in Figure 2-2.

1. Strip outer insulation from both ends, exposing the braided or spiral wrapped shield. Do not cut the shield on the control end. Cut off the shield on the end away from the 2301A control.
2. Use a sharp, pointed tool to carefully spread the strands of the shield.
3. Pull the inner conductors out of the shield. Twist braided shields to prevent fraying.
4. Connect lugs to the shield and to the control wires. Connect the wires to the appropriate terminals on the control and the shield to the grounding lug below terminal 9.

Installations with severe electromagnetic interference (EMI) may require shielded wire run in conduit, double shielded wire, or other precautions. Contact Woodward or your authorized Distributor for additional information.

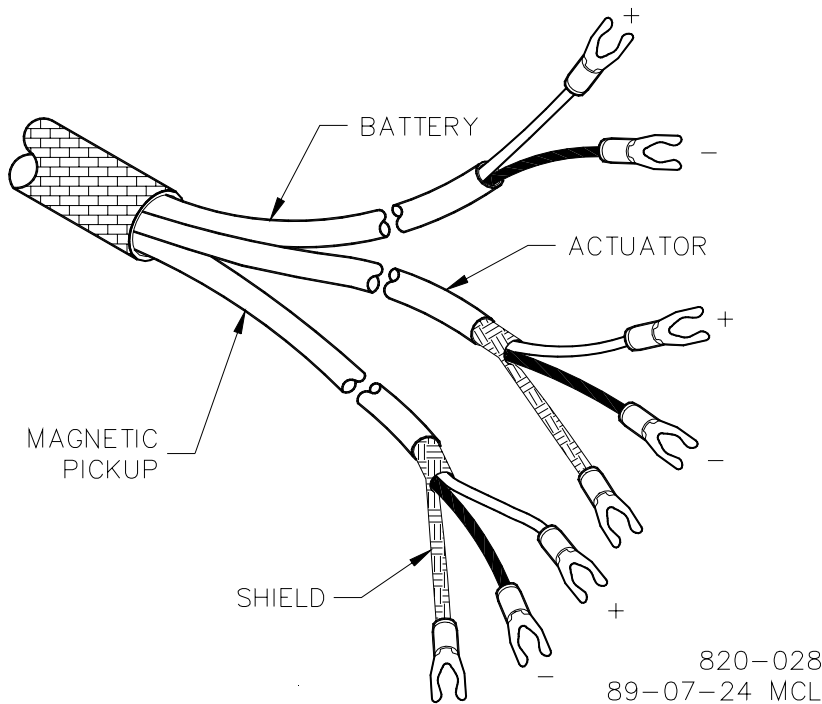

Figure 2-2. Preparation of Shielded Cables

Installation of Controls

The two controls used for split shaft or tailshaft governing are normally installed on the same control panel. Only limited access to the electronic panels is needed after initial calibration. The panels should be installed in areas with adequate ventilation to prevent excessive heat buildup which could seriously limit the life of the controls.

Outline drawings are provided in the appropriate manuals for the controls being used. Wiring diagrams for systems are provided in this manual.

Power Supply

The 10 to 40 Vdc power supply should be provided through wires dedicated exclusively for the governors. Do not draw power from a distribution point. A single power supply may be used for both controls.

Use 0.8 mm² (18 AWG) wire to connect power to the units.

If a battery is used for operating power, an alternator or other battery charging device is necessary to maintain a stable supply voltage.



CAUTION—BATTERY

To prevent damage to the control, make sure that the alternator or other battery-charging device is not connected to the control when the battery is disconnected from the control.

External Adjustments

Speed Trim

A speed-trim potentiometer or digital reference unit may be connected to terminals 11 and 12. Use a high quality 100 Ω , 10-turn potentiometer (Woodward part 1657-537 or equivalent) to provide about $\pm 5\%$ speed adjustment. Terminals 11 and 12 must be jumpered if the speed trim potentiometer or digital reference unit is not used. The 2301A Speed Control has a jumper installed at the factory which must be removed if a speed-trim device is used.

Most split shaft installations will need the speed trim potentiometer only on the N2 (tailshaft) governor. The trim may be installed on the N1 (engine) governor if desired and then run out of the way (fully clockwise) for normal operation.

Droop Potentiometer

Droop should only be used on the N2 (tailshaft) governor. If the potentiometer is installed on the N1 (engine) governor, it must be run out of the way (fully counterclockwise) during normal operation.

A 2K potentiometer may be connected to provide a maximum of about 8 percent droop. Connect the potentiometer counterclockwise end to terminal 15, clockwise end to terminal 14, and wiper to terminal 13. If droop is not desired, make no connections to terminals 13 and 14 (see Figures 2-3 and 2-4).

Switch Options

Minimum Fuel Contact

The minimum-fuel contact between terminals 2 and 3 is intended as an optional means for a normal shutdown of the prime mover. The contact is connected as shown on the plant wiring diagram. If a minimum fuel contact is not used, the terminals must be permanently jumpered. Most systems can only use the N1 governor for shutdown, and will have these contacts on the N2 governor jumpered. If the system uses the optional bleeder circuit to prevent shutdown, when N2 is above the set point too long, the minimum fuel contacts will not function correctly on the N2 governor.



WARNING—EMERGENCY STOP

Do NOT use the minimum-fuel contact as a part of any emergency-stop sequence. The emergency may be caused by a governor malfunction which would also cause a malfunction of the minimum-fuel feature. Use of the minimum-fuel contact for an emergency-stop sequence might not be able to prevent overspeed of the prime mover which could then cause mechanical damage and/or personal injury, including death.

Failed Speed Signal Override

Circuits in each of the 2301A Speed Controls constantly monitor the signal from the appropriate MPU. Should this signal be below a minimum threshold, the control sends a minimum-fuel signal to the actuator.

Before start-up of the prime mover, the speed signal is non-existent, activating the failed-speed-signal circuit. On units with cranking motors, the cranking speed is usually sufficient to provide a speed signal, so an override contact is not needed for starting.

A momentary switch should be installed where overriding the failed speed-signal circuit is required for start-up. The momentary switch ensures that the failed-speed-sensor circuit will be enabled after start-up. Either governor can prevent start-up with the failed MPU circuit. If it is necessary to override one of the circuits it will often be necessary to override both controls. It is possible that the N2 (tailshaft) governor will require an override when the engine is at idle. The optional bleeder circuit across the actuator output of the N2 control, if used, will provide bypass current to maintain idle speed, but this may not be enough to start.

Idle/Rated Ramp Contact

Connect a single-pole, single throw switch to terminal 5 on the N1 (engine) governor as shown on the appropriate plant-wiring diagram. Close the contact for rated, open for idle. Engine oil pressure is often used to close this contact. When closed, 10 to 40 Vdc is applied to terminal 5, and the prime mover can be operated at a speed higher than idle. When the contact is open, the voltage is removed from terminal 5, and the prime mover's speed decelerates to idle.

The N1 governor must be set for rated before the N1 set point will be high enough for the N2 governor to control.

A jumper is usually installed across the Idle/Rated terminals on the N2 governor, keeping this unit always at the rated speed as determined by the speed-trim potentiometer and the governor setting.

Acceleration Ramp

The ramp rate applies only to the acceleration mode. When the ramp-time potentiometer is full clockwise, the ramp time from idle to rated is 22 ± 4 seconds. When the ramp-time potentiometer is fully counterclockwise, the ramp rate is less than 1 second from idle to rated. The N2 governor should always have the ramp rate set fully counterclockwise, because the system is designed to respond to load changes as quickly as possible when under N2 governor control.

Actuator Output

The wire from terminal 9 of the N1 (engine) governor is connected to the positive (+) terminal on the actuator. The wire from terminal 10 of the N1 governor is connected to terminal 12 on the N2 (tailshaft) governor. The wire from terminal 10 on the N2 governor then completes the circuit to the common (-) post on the actuator.

The optional bleeder circuit within the actuator circuit provides a minimum-fuel position for the actuator when the N2 speed is at rated or above. If this bleeder circuit is not in place, the N2 governor will call for shutdown-fuel position when the speed sensed by the N2 MPU is above rated.

Turn the bleeder circuit potentiometer clockwise to increase the minimum fuel position.

The use of the optional bleeder circuit makes it impossible to shut down the engine or turbine from the N2 governor. This makes it important to install the shutdown contacts on the N1 governor and to jumper the shutdown contacts on the N2 governor.

Use shielded wires with the shield connected to the grounded post on the panel of the N2 governor. Do not connect the shield to the actuator or to any other point. The shield must have continuity the entire distance to the actuator and must be insulated from all other conductors. Proper shielding of the actuator leads is important to the operation of the dual governor installation.

**NOTE**

Electromagnetic Interference (EMI) can be an intermittent condition. Improperly shielded installations can provide good control for a while and then cause problems. For this reason it is important to be sure that all shields are properly installed.

Speed Sensor

Connect a speed-sensing device (usually an MPU) from the gear being sensed by the particular governor to terminals 8 and 7 of the particular governor. No polarity is observed. Use shielded wire and connect the shield only at the 2301A control. The shield must have continuity the entire distance to the MPU. Insulate the shield from all other conductors and from the MPU.

Frequency and Phase Matching with an SPM-A Synchronizer (Generation Equipment Only)

Connect the SPM-A (optional equipment) wires to terminals 15 (+/-) and 16 (com) of the N2 governor. Use shielded wire and connect the shield to the ground.

Auxiliary Input

(Generation Equipment Only)

Terminals 17 (-) and 15 (+) of the N2 governor are used for auxiliary input from a load sensor. Use of the load sensor and parallel lines allow the 2301A Speed Control to be used in isochronous load-sharing circuits. If the load sensor is not used, N2 droop must be used to share load. (An exception is a multiple-engine installation in which one engine is operated isochronously and all other engines are operated in droop.)

Installation Check-Out Procedure

When the installation is completed, perform the following check-out procedure before beginning the start-up adjustments in Chapter 4.

1. Visual Inspection:
 - a. Check the linkage between the actuator and the prime mover for looseness or binding. Refer to the appropriate actuator manual, and Manual 25070, *Electronic Control Installation Guide*, for additional information on linkage.

**WARNING—MINIMUM FUEL LINKAGE**

The actuator lever should be near, but not at, the minimum position when the fuel setting is at the minimum position. This could avoid a dangerous condition caused by an engine or turbine which will not shut down.

- b. Check for correct wiring according the plant wiring diagram.
 - c. Check for broken terminals and loose terminal screws. Make sure all terminal lugs are carefully and correctly installed. (Incorrectly installed crimp-on terminals can cause governor failure.)
 - d. Check the speed sensor (MPU) for visible damage. Check the clearance between the gear and the sensor, and adjust if necessary. See Manual 82510, *Magnetic Pickups and Proximity Switches for Electronic Controls*.
2. Check for Grounds.

With the power off, check for grounds by measuring the resistance between each terminal and the grounding bolt located below terminal 9. Terminals 1 and 2 are power-input terminals. Either of these terminals may be grounded in accordance with local codes or through other equipment powered from the same supply. If either is grounded, a high resistance to ground will be evident at terminals 1 through 5 on low voltage models, and terminals 1 through 4 on high voltage models. Grounds present on these terminals will not normally affect operation, unless they interfere with the input power or switching logic. Grounds on terminals 7 through 17, detected by readings other than infinity, should be located and removed.

Dynamic Adjustment

Adjust each of the controls separately to provide the proper dynamic response of the engine or turbine. Short out the actuator series connection on the control not being adjusted according to the notes on the plant wiring diagram for the appropriate installation.

**WARNING—START-UP**

Be prepared to make an emergency shutdown when starting the engine, turbine, or other type of prime mover, to protect against runaway or overspeed with possible personal injury, loss of life, or property damage.

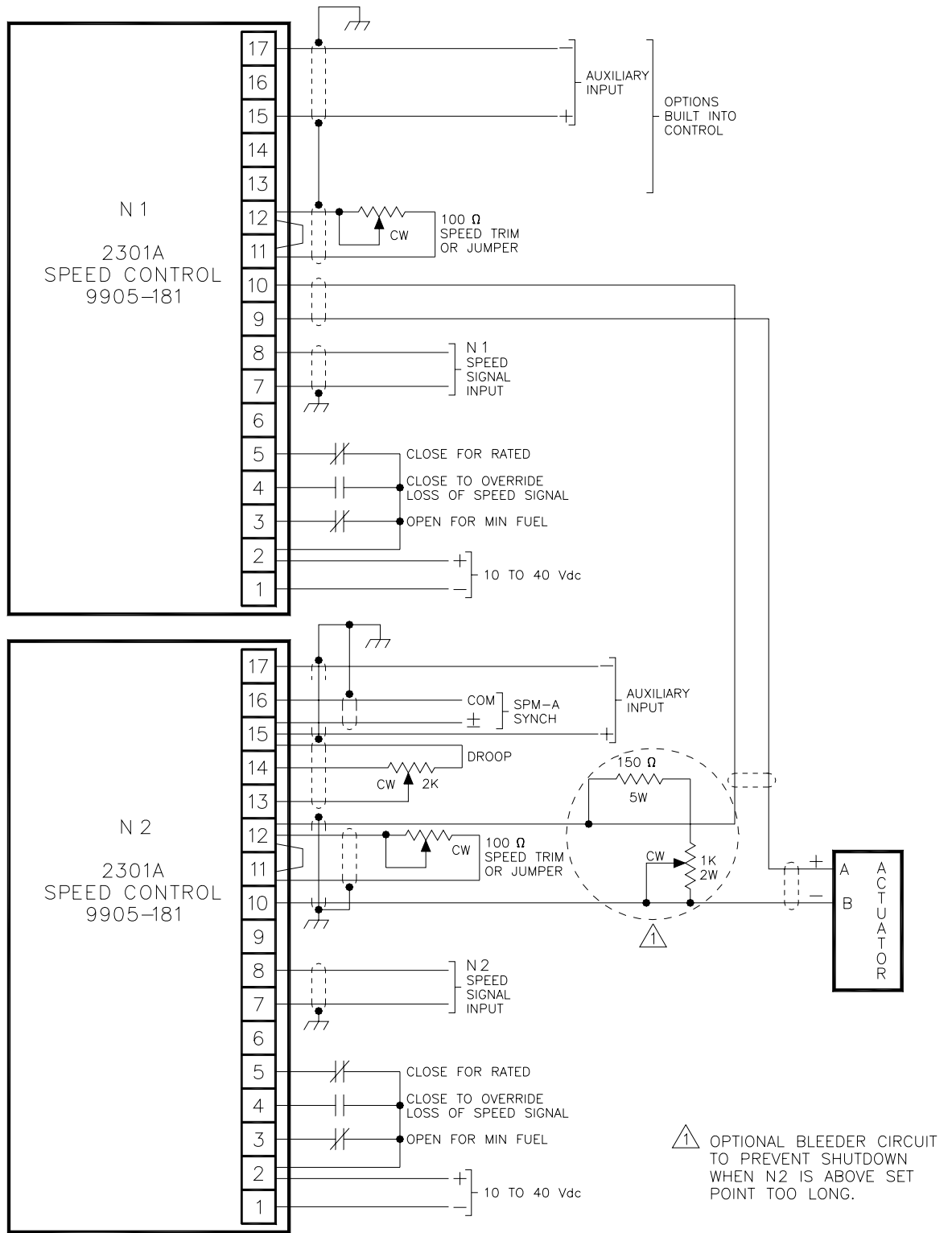

FOR INITIAL ADJUSTMENT
SHORT TERMINAL 10 TO 12
ON CONTROL NOT BEING
ADJUSTED TO KEEP IT
FROM INTERFERING

TORQUE CONVERTER
SPEED CONTROL
PLANT WIRING

⚠ OPTIONAL BLEEDER CIRCUIT
TO PREVENT SHUTDOWN
WHEN N2 IS ABOVE SET
POINT TOO LONG.

013-002
93-4-22 RAM

Figure 2-3. Plant Wiring Diagram, Split Shaft Speed Control

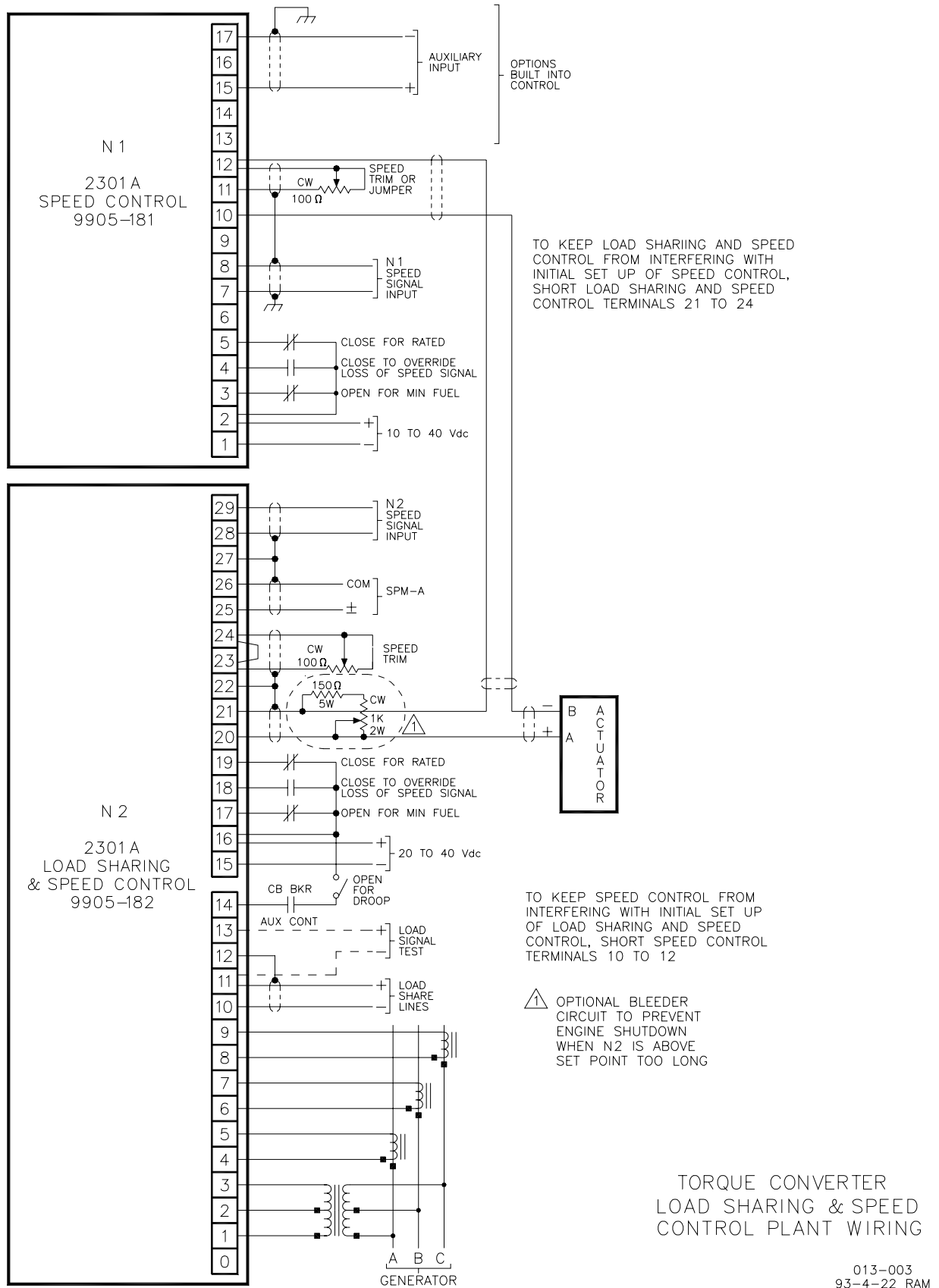

Figure 2-4. Plant Wiring Diagram, Split Shaft Load Sharing and Speed Control

We appreciate your comments about the content of our publications.

Send comments to: icinfo@woodward.com

Please include the manual number from the front cover of this publication.



PO Box 1519, Fort Collins CO 80522-1519, USA
1000 East Drake Road, Fort Collins CO 80525, USA
Phone +1 (970) 482-5811 • Fax +1 (970) 498-3058

Email and Website—www.woodward.com

**Woodward has company-owned plants, subsidiaries, and branches,
as well as authorized distributors and other authorized service and sales facilities throughout the world.**

Complete address / phone / fax / email information for all locations is available on our website.