

505 Digital Control for Steam Turbines

Applications

The 505 controller is designed to operate industrial steam turbines of all sizes and applications. This steam turbine controller includes specifically designed algorithms and logic to start, stop, control, and protect industrial steam turbines or turbo-expanders, driving generators, compressors, pumps, or industrial fans.

The 505 control's unique PID structure makes it ideal for applications where it is required to control steam plant parameters like turbine speed, turbine load, turbine inlet header pressure, exhaust header pressure, or tie-line power.

The control's special PID-to-PID logic allows stable control during normal turbine operation and bumpless control mode transfers during plant upsets, minimizing process over- or undershoot conditions. The 505 controller senses turbine speed via passive or active speed probes and controls the steam turbine through one or two (split-range) actuators connected to the turbine inlet steam valves.

The 505 controller also includes the following turbine protection functions to ensure that the turbine or its driven load (compressor, pump, generator) is not operated outside of its designed limits:

- 3 Critical speed avoidance bands
- Overspeed anticipation and shutdown protection
- Configurable under- or over-pressure shutdown logic
- Minimum and maximum speed and load settings

Ethernet and serial communications allow users to easily connect the 505 into the plant or process control system. All controller inputs, outputs, and statuses can be monitored, and all start/stop or enable/disable commands can be given through industry standard Modbus[®] * TCP or OPC protocols. The 505 uses SNTP (synchronized network time protocol) over Ethernet to allow users to synchronize the 505's real-time clock to the plant distributed control system.

* Modbus is a trademark of Schneider Automation Inc.

Description

The 505 control is packaged in an industrial hardened enclosure designed to be mounted within a system control panel located in a plant control room or next to the turbine. The control's front panel serves as both a programming station and operator control panel (OCP). This user-friendly front panel allows engineers to access and program the unit to the specific plant's requirements, and plant operators to easily start/stop the turbine and enable/disable any control mode. Password security is used to protect all unit program mode settings. The controller's 8.4-inch (21 cm) graphical display allows operators to view actual and setpoint values from the same screen, simplifying turbine operation.

Turbine interface input and output wiring access is located on the controller's lower back panel. Un-pluggable terminal blocks allow for easy system installation, troubleshooting, and replacement.



- Field-configurable
- Integrated graphical operator control panel
- Automatic start routines
- Integrated first-out problem indicator
- Trip and Alarm event recorder
- User-friendly menu format
- Real-time trend screens
- Turbine run-time logs
- Real-time clock synchronization via SNTP
- Ethernet communications
- Same form-fit-function as previous 505 versions
- Sulfur-resistant conformal coating
- Certified for Hazardous Locations (low-voltage models)

Designed for steam turbine control, the 505 control includes four PID controllers (Speed, Cascade, Aux-1, Aux-2), multiple start-up routines (manual, semi-auto, automatic, remote control), and multiple protection functions (overspeed, critical speed range, max power, etc.) which can be configured by a user depending on the specific turbine application's requirements. Users can configure the 505's different PID controllers, start routines, and protection levels themselves without the need for a special control engineer. Once configured, the 505 performs a configuration check routine to ensure that the programmer did not make any basic configuration mistakes.

Optionally, users can utilize Woodward's RemoteView software program with the 505 to function as a remote

operator control panel and/or engineering station. Once loaded onto a remote computer or touch panel, this software program allows the computer or touch panel to perform all of the 505 front panel display functions (monitor, operate, tune, and configure). Password-based login level security allows users to manage which functions they want the remote panel user to have. Refer to product specification 03424 for more information on RemoteView's capabilities.

The 505 includes a suite of service tools to allow users to perform the following functions:

- Download configuration settings files to the 505
- Upload configuration settings files from the 505 to save on another device
- View real-time or saved trend files

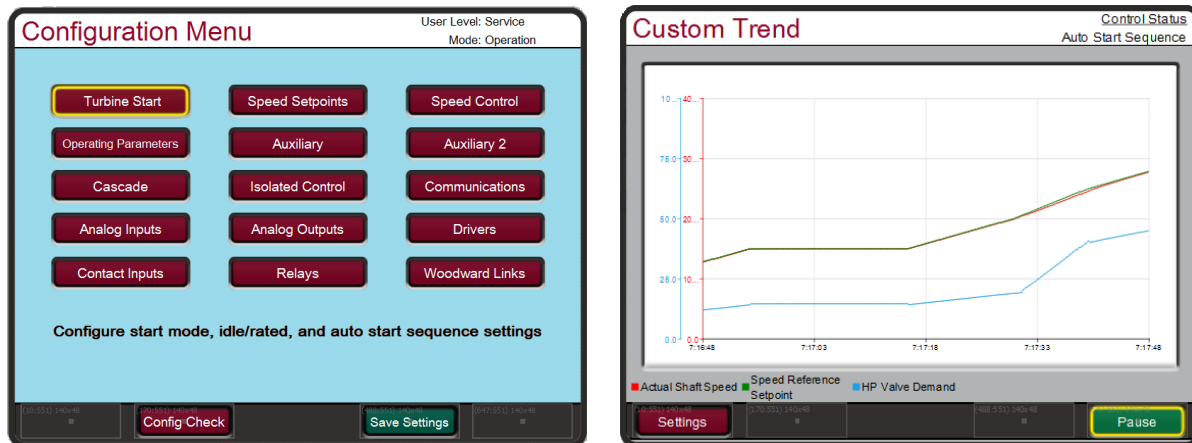

Figure 1. Example RemoteView Screens

Cost-Effective Design

The 505 control is designed to function as the turbine control, system sequencer, operator control panel, and first-out indicator. This encompassing design minimizes external system devices as well as system installation, wiring, and troubleshooting.

This field-configurable controller allows major functional changes to be made on-site, often by knowledgeable plant personnel, and minor functional changes to be on-line as process changes require. The 505 control's first-out-indicator logic indicates internal as well as external system related alarm and shutdown conditions, greatly simplifying and reducing system troubleshooting.

Communications

The 505 controls can communicate directly with plant Distributed Control Systems and/or CRT-based operator control panels, through four Ethernet ports using Modbus TCP or OPC communication protocols, or via one serial Modbus port. The single serial port supports RS-232 or RS-485 communications using ASCII or RTU Modbus protocols.

Communications between the 505 and a plant DCS can also be performed through hard-wired connections.

Control

The following PIDs are available to perform as process controllers or limiters:

- Speed/Load PID (with multiple dynamics & Adaptive PID)
- Auxiliary PID 1 (limiter or control)
- Auxiliary PID 2 (limiter)
- Cascade PID (Header Pressure or Tie-Line Control)

System Protection

- Integral Overspeed Protection Logic & Test Capability
- First-out Indication (10 individual shutdown inputs)
- Stuck in critical speed band logic
- Bumpless transfer between control modes if a transducer failure is detected
- Local/Remote Control priority and selection
- Fail-safe Shutdown Logic
- Mode login level password security

Control Specifications

INPUTS

- Power: LV models = 18–32 Vdc
HV models = 88–264 Vac & 90–150 Vdc
- Speed: 2 Passive MPUs or 2 Active Proximity probes (0.5–32 000 Hz)
- Discrete Inputs: 20 Configurable Contact Inputs
- Analog Inputs: 8 Configurable 4–20 mA Inputs

OUTPUTS

- Valve/Actuator Drivers:
2 Actuator Outputs, 4–20 mA or 20–200 mA
- Discrete Outputs:
8 configurable Relay Outputs (2 relays rated for 24 Vdc @ 5 A, 6 relays rated for 24 Vdc @ 2 A)
- Analog Outputs:
6 Programmable 4–20 mA Current Outputs

COMMUNICATIONS

- Ethernet: 4 ports (Modbus TCP or OPC protocols)
- Serial: 1 Modbus port (ASCII or RTU) Comm Ports (RS-232 or RS-485 compatible)
- CAN: 4 ports (Woodward CANopen protocol)

Functionality

The 505's control capabilities are:

- Speed/Frequency Control
- Turbine or Generator Load Control or Limiting
- Turbine Inlet Header Pressure Control or Limiting
- Turbine Exhaust Header Pressure Control or Limiting
- Plant Import/Export Power Control or Limiting
- Isochronous Load Sharing between units (with DSLC™-II control)
- Control of any process directly related to unit load

Features

- Critical Speed Avoidance (3 speed bands)
- Auto Start Sequence (hot & cold starts)
- Valve Limiter(s)
- Security (program is password protected)
- Adaptive Speed/Load PID Dynamics
- First-Out Indication (shutdowns)
- Zero Speed Detection with proximity probe (< 0.5 Hz)
- Peak Speed Indication for overspeed trip
- Multi-lingual Display (English & Chinese)

Operating Conditions

- -30 to +70 °C ambient air temperature range
- Humidity: Lloyd's ENV2 test #1
- Dry Heat: Lloyd's ENV3
- Salt Fog: US MIL-STD-810 method 509.2 procedure 1
- Shock: meets US MIL-STD-810C, method 516.2-1, procedure 1B
- Vibration: Lloyd's ENV2 test #1

Pollution Resistance

- Particulate Pollution Resistance: IEC 664-1 Pollution Degree 2 (normally only non-conductive pollution occurs)
- IEC 60068-2-60:1995 Part 2.60 Methods 1 and 4 (Flowing Mixed Gas Corrosion Test)
- Gaseous Pollution Resistance: Module conformal coating withstands NO₂, CO₂, SO₂, and H₂S gases
- Will withstand levels typical of telecommunications and computer installations as defined by Battelle Labs Class III (between IEC60721-3-3 classification 3C1 and 3C2, light industrial to urban industrial, heavy traffic)

Regulatory Compliance—**PENDING**

European Compliance for CE Marking

These listings are limited to only those units bearing the CE Marking.

- EMC Directive: 2006/95/EC COUNCIL DIRECTIVE
- ATEX Directive: 94/9/EC COUNCIL DIRECTIVE Zone 2, Category 3, Group IIG Ex nA [ic] IIC T4 X IP20

Other International Compliance

- CU-TR: Certified for use in explosive atmospheres within the Customs Union per certificate CU-RU-CU-TR C-US-xxxxxxxxx US.xxx as 2 Ex nA [ic] IIC T4 X

North American Compliance

- CSA Listed for Class I, Division 2, Groups A, B, C, and D, T4 at +70 °C

Marine Compliance

- Lloyd's Register (LR): Environmental Category ENV1, ENV2, ENV3, Lloyd's Register Type Approval Test Specification Number 1, July, 2013

- Remote analog setpoints for Speed/Load, Aux, and Cascade
- High Speed Digital Communications to Woodward actuators and power management products

Control Accessories

RemoteView—Once installed on a computer or touch panel, the RemoteView software program can be used as an engineering workstation and/or remote operator control panel. As an operator control panel, this software program can be used to monitor all system parameters, start and stop the turbine, and enable/disable all modes of operation.

Control Assistant—The Control Assistant software program functions as an engineering workstation and/or service tool that can be used with the 505 control to view real-time trends, view saved trend files, or compare differences in configuration files. As an engineering workstation, this software program can be used to upload and download settings and log files to and from the 505 controller (details in product spec 03424).

AppManager—Tool for setting the IP addresses of the Ethernet ports, setting SNTP functionality, Program upload/download capability, retrieving datalog files, Start/Stop the Display program (to change languages).

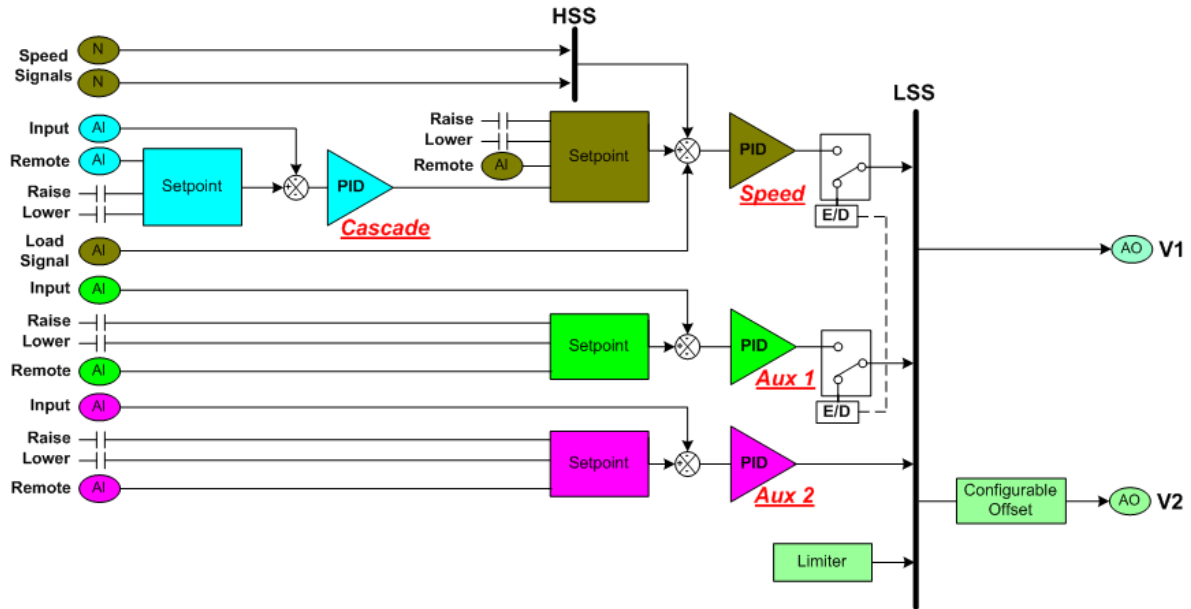

Figure 2. Basic Functional Control Diagram

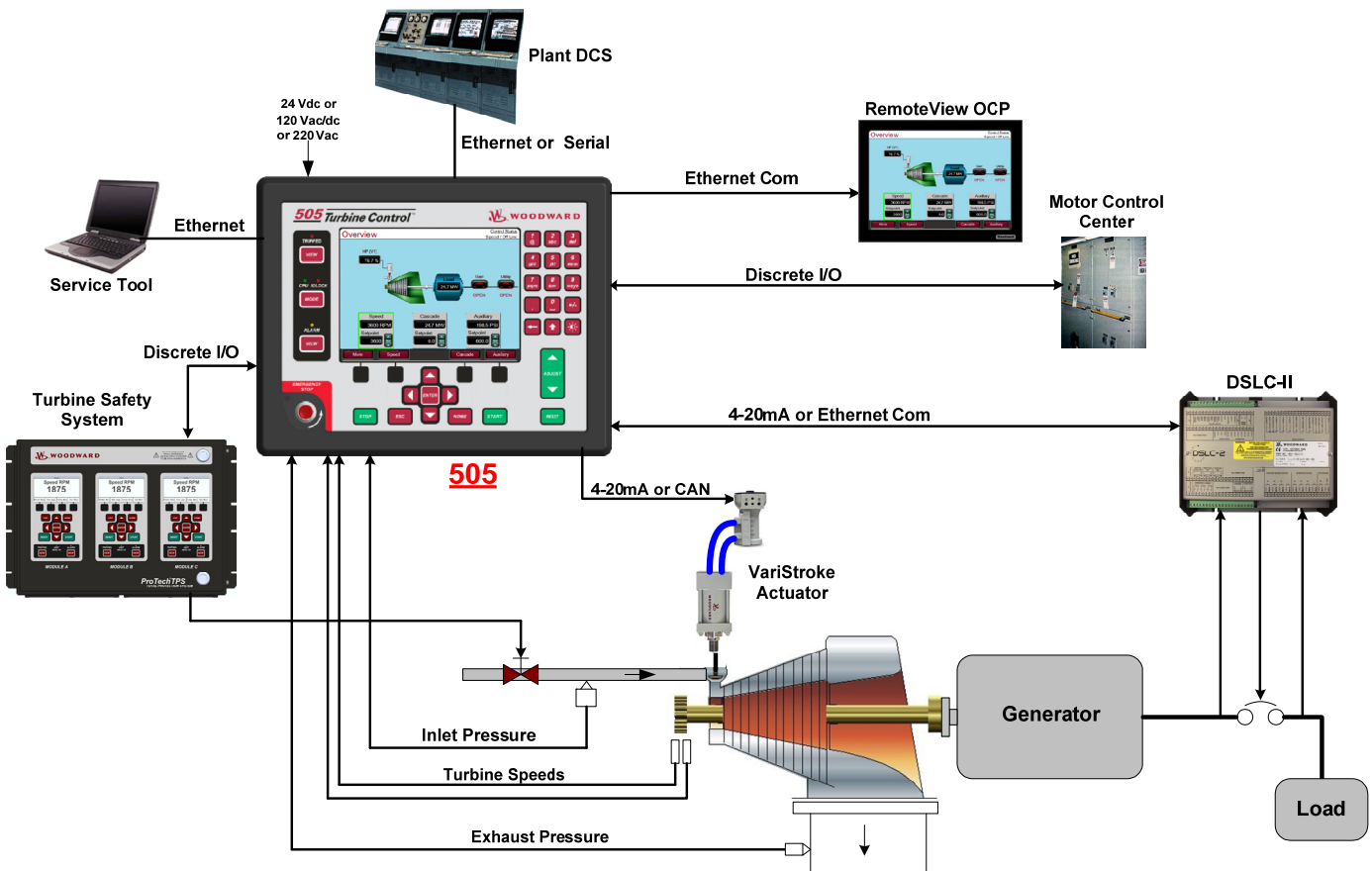

Figure 3. Typical 505 Application

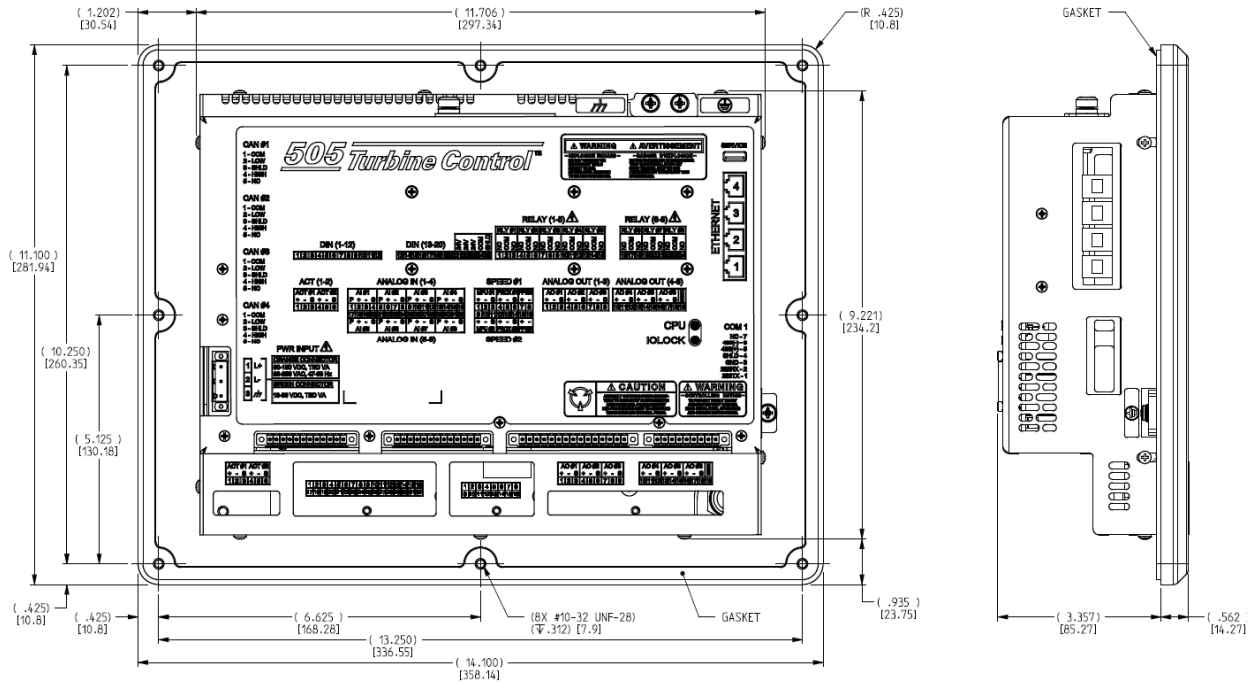

Figure 4. 505 Dimensions
 (Do not use for construction)



PO Box 1519, Fort Collins CO 80522-1519, USA
 1000 East Drake Road, Fort Collins CO 80525, USA
 Phone +1 (970) 482-5811 ♦ Fax +1 (970) 498-3058
 Email and Website—www.woodward.com

Woodward has company-owned plants, subsidiaries, and branches, as well as authorized distributors and other authorized service and sales facilities throughout the world. Complete address / phone / fax / email information for all locations is available on our website.

This document is distributed for informational purposes only. It is not to be construed as creating or becoming part of any Woodward contractual or warranty obligation unless expressly stated in a written sales contract.

Copyright © Woodward 2015, All Rights Reserved

For more information contact: