

36529



Digital Governor Systems

**APECS[®] Plus 1, Plus 2, Plus 4,
Plus 6 Actuator & Electronic
Controller Systems**

User Manual

Manual 36529



WARNING

Read this entire manual and all other publications pertaining to the work to be performed before installing, operating, or servicing this equipment. Practice all plant and safety instructions and precautions. Failure to follow instructions can cause personal injury and/or property damage.

The engine, turbine, or other type of prime mover should be equipped with an overspeed shutdown device to protect against runaway or damage to the prime mover with possible personal injury, loss of life, or property damage.

The overspeed shutdown device must be totally independent of the prime mover control system. An overtemperature or overpressure shutdown device may also be needed for safety, as appropriate.



CAUTION

To prevent damage to a control system that uses an alternator or battery-charging device, make sure the charging device is turned off before disconnecting the battery from the system.

Electronic controls contain static-sensitive parts. Observe the following precautions to prevent damage to these parts.

- Discharge body static before handling the control (with power to the control turned off, contact a grounded surface and maintain contact while handling the control).
- Avoid all plastic, vinyl, and Styrofoam (except antistatic versions) around printed circuit boards.
- Do not touch the components or conductors on a printed circuit board with your hands or with conductive devices.

Woodward Governor Company reserves the right to update any portion of this publication at any time. Information provided by Woodward Governor Company is believed to be correct and reliable. However, no responsibility is assumed by Woodward Governor Company unless otherwise expressly undertaken.

© Woodward 2004
All Rights Reserved

Contents

ELECTROSTATIC DISCHARGE AWARENESS	II
CHAPTER 1. GENERAL INFORMATION	1
Introduction.....	1
Auxiliary Control Modules.....	2
Controller Inputs	2
Typical Applications.....	3
CHAPTER 2. SPECIFICATIONS & DIMENSIONS	4
Electrical.....	4
Mechanical	4
Performance.....	4
Dimensions.....	5
CHAPTER 3. INSTALLATION	6
Actuator and Electronic Assembly	6
Mounting Actuator and Linkage	6
Installation of Speed Sensor (Magnetic Pickup)	6
Installation and Wiring.....	7
Checking for Proper Installation	8
Required Tools	8
Plus 1 & Plus 4 Wiring Diagrams	9
Wiring for CE Controllers	10
Dimensions	10
Typical Installation Diagram.....	11
Typical Plus 1 or Plus 4 Basic Governor Wiring	12
Plus 2 Wiring Diagrams.....	13
Wiring for CE Controllers	14
Dimensions	14
Typical Plus 2 Actuator Wiring.....	14
Plus 6 Wiring Diagrams.....	15
Typical Panel and Terminal Strip Wiring.....	15
Typical Plus 6 Explosion Proof Governor Wiring.....	16
Typical Panel and Terminal Strip Wiring.....	16
CHAPTER 4. CALIBRATION AND ADJUSTMENTS	17
Calibration and Adjustment Tips	19
Adjustment Configurations	20
CHAPTER 5 DIAGNOSTICS & TROUBLESHOOTING	22
CHAPTER 8. SERVICE OPTIONS	28
Product Service Options.....	28
Replacement/Exchange.....	28
Flat Rate Repair	29
Flat Rate Remanufacture.....	29
Returning Equipment for Repair.....	29
Packing a Control.....	29
Return Authorization Number	30
Replacement Parts	30
How to Contact Woodward.....	30
Engineering Services	31
Technical Assistance.....	32

Electrostatic Discharge Awareness

All electronic equipment is static-sensitive, some components more than others. To protect these components from static damage, you must take special precautions to minimize or eliminate electrostatic discharges.

Follow these precautions when working with or near the control.

1. Before doing maintenance on the electronic control, discharge the static electricity on your body to ground by touching and holding a grounded metal object (pipes, cabinets, equipment, etc.).
2. Avoid the build-up of static electricity on your body by not wearing clothing made of synthetic materials. Wear cotton or cotton-blend materials as much as possible because these do not store static electric charges as much as synthetics.
3. Keep plastic, vinyl, and Styrofoam materials (such as plastic or Styrofoam cups, cup holders, cigarette packages, cellophane wrappers, vinyl books or folders, plastic bottles, and plastic ash trays) away from the control, the modules, and the work area as much as possible.
4. Do not remove the printed circuit board (PCB) from the control cabinet unless absolutely necessary. If you must remove the PCB from the control cabinet, follow these precautions:
 - Do not touch any part of the PCB except the edges.
 - Do not touch the electrical conductors, the connectors, or the components with conductive devices or with your hands.
 - When replacing a PCB, keep the new PCB in the plastic antistatic protective bag it comes in until you are ready to install it. Immediately after removing the old PCB from the control cabinet, place it in the antistatic protective bag.



CAUTION

To prevent damage to electronic components caused by improper handling, read and observe the precautions in Woodward manual 82715, *Guide for Handling and Protection of Electronic Controls, Printed Circuit Boards, and Modules*.

Chapter 1.

General Information

Introduction

This manual describes the installation, operation, and calibration of the APECS Plus 1, Plus 2, Plus 4, and Plus 6 all-electric governor systems. The basic governor assembly consists of an actuator and controller. The units are electrically coupled together to make a complete governor system offering optimum engine control.

A typical system would also have an on-off switch, a magnetic pickup and a remote speed potentiometer. The magnetic pickup detects engine speed (RPM) from gear teeth on the prime mover. This signal, the remote speed signal, and DC power, are brought into the controller for processing to allow for optimum engine control.

No special requirements are needed for mounting the APECS actuator on the engine. It can be located at any convenient position since there are no requirements for a mechanical drive or oil connections.

Electronic Control Box

This rugged container houses the electrical components used in controlling the actuator output and ultimately the engine. The components and container are designed to withstand 20 G's of mechanical vibration through 500 Hz. The control box is mounted directly on the actuator and is electrically connected to the actuator through a 5 pin connector.

The electronic control box receives electrical input signals from both the magnetic speed sensor and the reference speed pot. These signals are processed and compared, resulting in an error signal that is amplified and sent to the actuator in a proportional, integral and derivative summation. When the actuator receives the desired output shaft electrical signal, the output shaft rotates and a feedback is sent and compared to the desired signal. Any difference is transmitted to the power amplifier, which sends corrective action to the output shaft position.

Junction Box

An optional junction box can be used to house the reference speed potentiometer and the power switch. It can be mounted for convenient connection to the electronic control box, power source, and magnetic speed sensor.

Magnetic Speed Sensor

The magnetic speed sensor, typically mounted on the flywheel housing, generates electrical pulses proportional to speed by sensing magnetic material, i.e., teeth on the engine ring gear passing the sensor.

Actuators

The actuators are electrically connected to the electronic control box and their mechanical output is connected to the engine's fuel system. Actuators are electrically powered and have output work capacities of 1, 2, 4, and 6 ft-lbs. The actuators convert an electrical input to an angular mechanical output at the output shaft, which has a maximum rotation of 45°.

Auxiliary Control Modules

Four auxiliary control modules are available:

- Isochronous load sharing control
- Auto-synchronizer
- Ramp generator
- Single phase load pulse control.

These and other auxiliary functions, such as remote speed setting and Kw limits, can be installed at the time of the initial governor installation or, just as easily, added later when the need arises. No modification to the basic governor is required when these auxiliary functions are added. In fact, if the prewired harness is used, the wires necessary to add these features are often already provided, further simplifying installation.

Controller Inputs

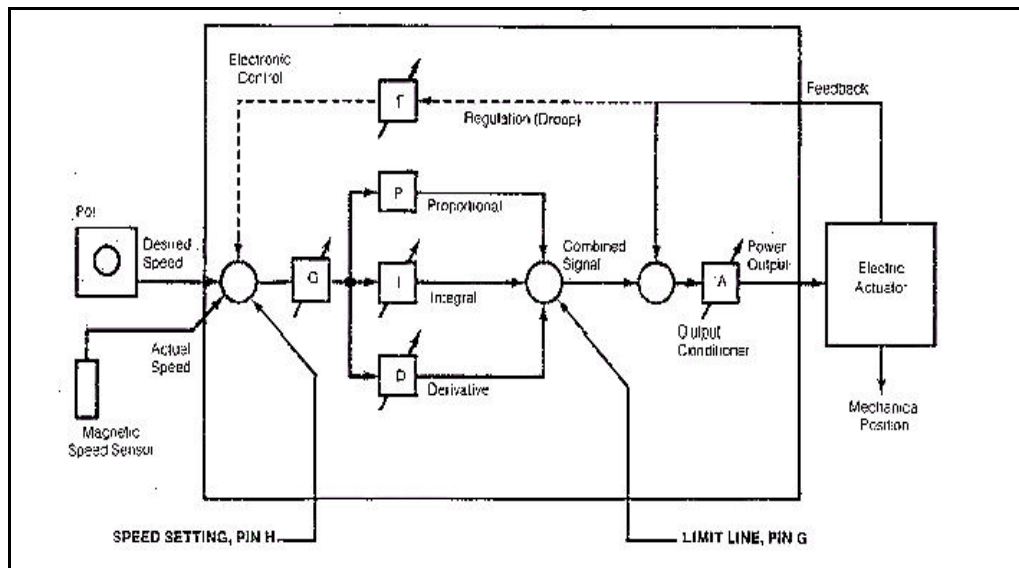

SPEED SETTING / Pin H

Modify speed with respect to:

- Remote Speed Setting
- Time (Ramp Generator)
- Electrical Load Change (Load Pulse)
- Electrical Load (Isochronous Load Sharing)
- Electrical Phase Angle (Synchronizer)

LIMIT LINE / Pin G

Limit fuel (rack or throttle position) with respect to:

- Maximum Fuel Permitted (Load Limit)
- Temperature (Exhaust)
- Manifold Pressure (Smoke Limit)
- Oil Pressure
- Time (some ramp generator applications)
- Requested Speed (Torque Limit)
- Actual Speed (Torque Limit)

Typical Applications

Speed Governing

APECS controllers are available for engine governing for speed and power control of piston and gas turbine engines where the fuel is controlled by the governor's output shaft. The controllers are also applicable for controlling steam and water turbines.

Tandem Engine Governing

The APECS controller provides the precise positioning required for accurate tracking of two governor actuators used for controlling tandem-coupled engines.

No-Break Engine Governing

APECS controllers are designed to provide dual-mode operation. The controller functions with fixed gain when the engine is declutched and with an adjustable high gain when the engine is coupled to the load.

Propulsion Governing

APECS controllers are available for engine governing of propulsion engine applications. The controller has an adjustable low limit feature which is required to maintain correct engine operation due to the loading characteristics of the propeller. The same controller should be used on tandem-coupled propulsion engine applications.

Wide Speed Range Governing

APECS controllers provide governing for speed and power control of piston and gas turbine engines where the fuel is controlled by the governor's output shaft. The controller is designed to provide improved governor performance and control over a wider speed range than standard speed governors.

Chapter 2. Specifications & Dimensions

Electrical

Operating Voltages:	12, 24, or 32 Volts ± .20%. Other voltages available by special request.
Maximum Output Current:	14 A
Output Signal:	Pulse width modulated current to APECS actuator

Mechanical

Ambient Operating Temperature:	-65°F to +200°F (-55°C to +95°C)
Enclosure:	Aluminum extrusion
Circuit Boards	Heavy conformal coating for moisture and vibration protection
Mechanical Vibration	Tested 5 Hz to 500 Hz @ 25 G's (peak level on governor)
Weight:	1.4 lbs (635 g)

Performance

Temperature Stability:	Better than ±5% over a temperature range of -65°F to +200°F (-55°C to +95°C)
Steady State Speed Band:	± 0.2%, isochronous control
Speed Regulation (Droop):	Adjustable from 0-15%. Remote adjustment optional

Input Signal Frequency

Select your controller for the correct input signal frequency range generated by the magnetic pickup at the maximum engine operated (RPM) speed. Use the following formula to convert from RPM to Hertz.

$$\frac{[(EngineRPM) \times (NumberOfTeeth)]}{[60s]} = [MpuHertz]$$

Dimensions

Dimensions in millimeters. Inches in brackets [].

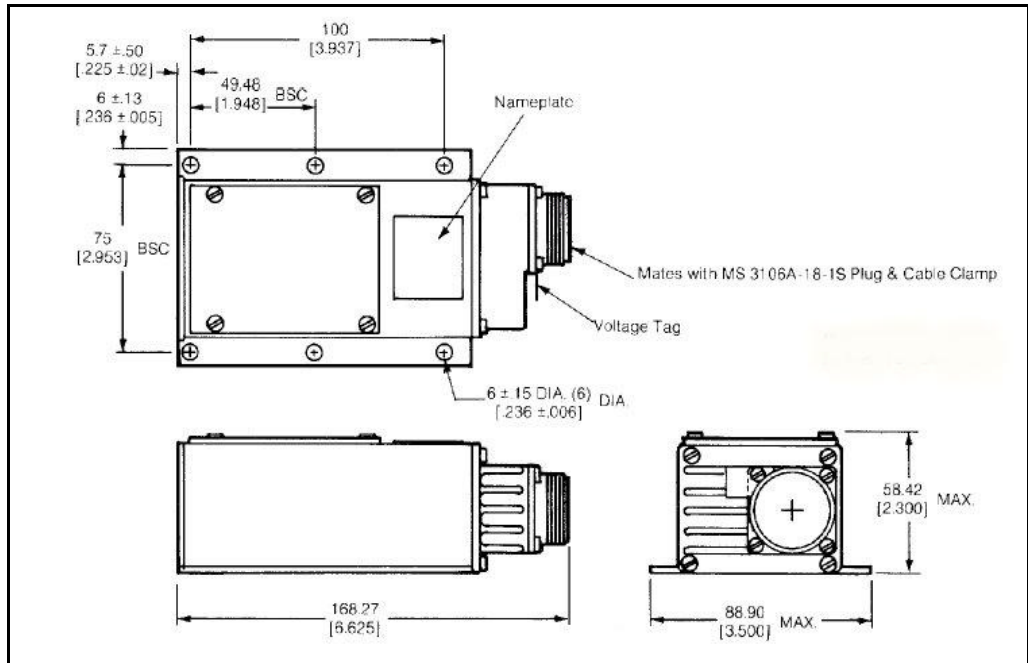

Chapter 3. Installation

Actuator and Electronic Assembly

The actuator and electronic assembly can be installed in any position by using a simple steel bracket or mounting pad. Be sure that the mechanical linkage has sufficient physical clearance to freely move from minimum to maximum fuel. The length of this linkage rod connecting the actuator output shaft to the engine fuel control should not be excessively long. Use 4" to 10" except in special cases.

NOTE: The Plus 4 actuators have through output shafts that rotate CW or CCW to increase fuel. The direction of rotation is determined when the output shaft is pointed toward the observer. The minimum fuel position is obtained when power is not applied to the actuator coil.

Mounting Actuator and Linkage

Adjust the linkage rod to allow at least 40° rotation of the actuator output shaft for full travel of the fuel control. Use lock nuts on the linkage rod. See Figure 1 for typical linkage arrangements.

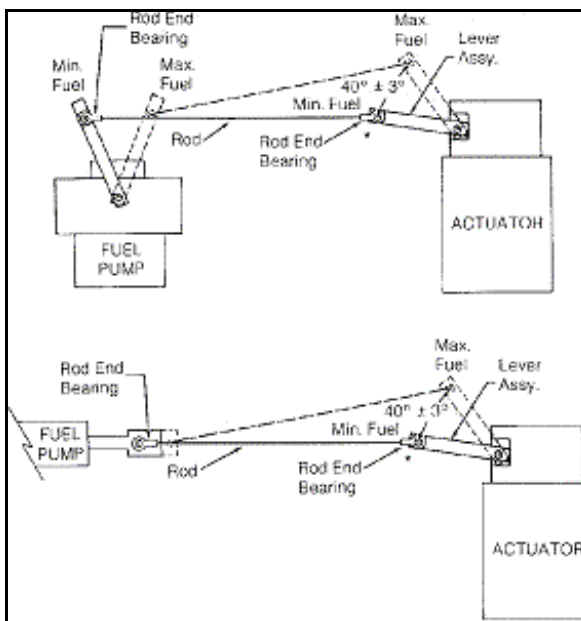

(*) Mount rod end bearing as close as possible to output shaft and still obtain correct actuator output shaft rotation ($40^\circ \pm 3^\circ$)

Figure 1—Typical Non-Linear Linkage Arrangements

Installation of Speed Sensor (Magnetic Pickup)

Remove the inspection cover over the ring gear teeth. The teeth should be free of burrs, excessive grease or dirt.

The magnetic pickup should not be installed in inspection covers. Inspect the ring gear housing and pick a location where a $37/64$ " hole can be drilled such that the

ring gear teeth will pass in front of the pickup pole face. After the hole is drilled, use a 5/8-18 starting tap to cut threads for the magnetic pickup, then run a bottom tap through the hole.

NOTE: The hole should be drilled as nearly perpendicular as possible over the ring gear teeth, as illustrated in Figure 2.

Manually rotate the ring gear until a tooth face is directly in the center of the tapped hole. Gently turn the magnetic pickup clockwise into the hole until it bottoms on the tooth, and back off 1/4 turn. Tighten the jam nut firmly.

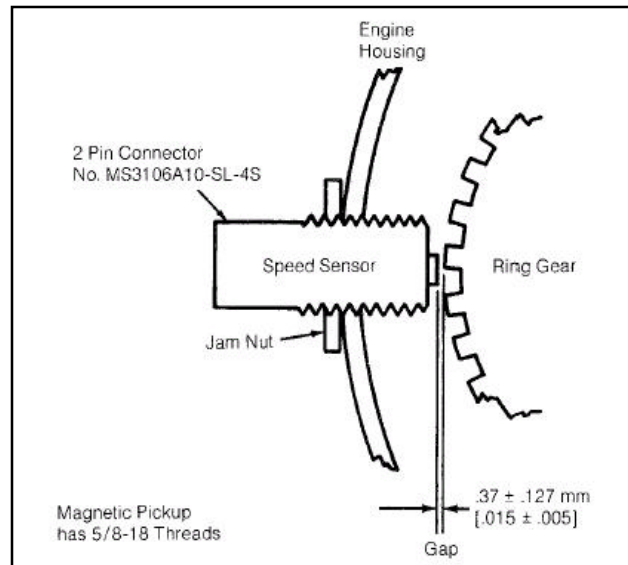

Turn in until pole face of pickup bottoms out on ring gear tooth and back out ¼ turn and tighten jam nut.

Figure 2—Installation of Magnetic Pickup

Installation and Wiring

Installation kits that include the mounting bracket and wiring harness are available for many engines. Contact the Woodward sales department for installation kit information.

Refer to the diagrams in the Wiring chapter for typical wiring of Plus 1, Plus 2, Plus 4, or Plus 6 APECS governor systems.

Important precautions to follow when making an installation:

1. Do not connect the control box connector to the wiring until proper voltage and polarity have been established.
2. Wiring:
 - (a) Use the recommended wiring cables shown in the Wiring chapter.
 - (b) Make sure the wire insulation will withstand the temperatures around the engine.
 - (c) Twist power leads.

- (d) Make sure that the end of shield not used is taped to prevent touching other components.
3. Ground shield installation procedures:
 - (a) On engines with positive ground systems, the shield lead on the two- and three-lead shielded cables must not be allowed to touch the engine frame or any part of the power system which is at the same potential as the engine frame. *Allowing the shield lead to touch any of these exposed parts will cause a short across the DC supply and could damage the control.*
 - (b) On engines with negative ground systems, the shield of the two- and three-lead shielded cables must not touch the engine frame. Letting the shield touch the engine frame or associated parts will not damage the control, but it may generate undesirable electrical signals that may cause unstable engine performance.
4. Observe the proper power supply polarity. The proper polarity to Pins A and C of the controller connector must be observed or the unit will not operate. Pin A must be connected to the positive terminal and Pin C to the negative terminal of the battery or power supply.

Checking for Proper Installation

1. After the wiring is mounted on the engine, connect the power wires; the red wire to the positive terminal, and the black wire to the negative terminal. (Do not connect power wiring to the engine frame—connect directly to the battery terminals.)
2. A voltmeter must be used at this time to check voltage at the electronic control box connector. Turn the power switch “ON” at the junction box. Connect the meter leads to Pins A and C of the connector. Pin A must be positive and Pin C negative. The meter should read rated battery voltage.
3. Place the power switch in the “OFF” position and connect the connector to the control box.
4. Remove top cover from control box.
5. Place a jumper between TP1 and TP2. (This overrides the failsafe feature.)
6. Place the power switch in the “ON” position. The actuator should move to the full fuel position.
7. Remove jumper between TP1 and TP2. (Actuator must return to minimum fuel position.)
8. Engine is ready to start.

CAUTION: As a safety measure, the engine should be equipped with an independent overspeed shutdown device in the event of failure which may render the governor inoperative.

Required Tools

Drill Bit — 3/64" diameter for magnetic pickup
Thread Tap — 5/8-18 starting tap for magnetic pick-up
Thread Tap — 5/8-18 bottom tap for magnetic pick-up
Soldering Iron — 50 Watt and Rosin Core Solder
Various pliers, wrenches, screwdrivers, wire strippers

Plus 1 & Plus 4 Wiring Diagrams

The available APECS panel mounted controllers and their input signal frequencies are noted below. Also listed are CE certified models.

Available in 12 or 24 Vdc.

Adjustments available: ACT, GAIN, DER, INT, LIM, DROOP, and SPEED (SPD)

Controller Part No.	Input Signal Frequency
Speed Controllers	
DYN1 10502-001	250 to 1200 Hz
DYN1 10503-001	1200 to 2500 Hz
DYN1 10504-001	2500 to 5000 Hz
DYN1 10506-001	5000 to 9500 Hz
CE Certified Controllers	
DYN1 10502-004	250 to 1200 Hz
DYN1 10503-004	1200 to 2500 Hz
DYN1 10504-004	2500 to 5000 Hz
DYN1 10506-004	5000 to 9500 Hz

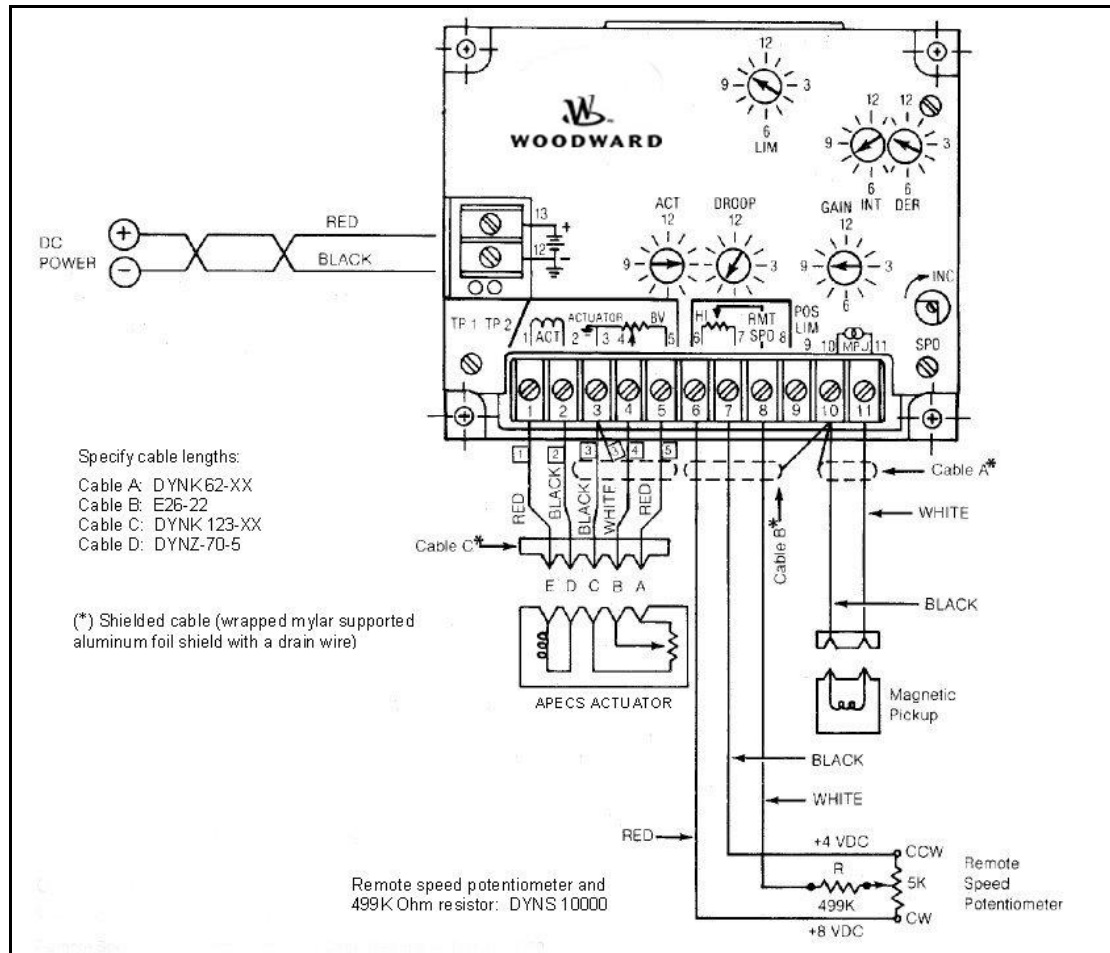

Wiring for CE Controllers

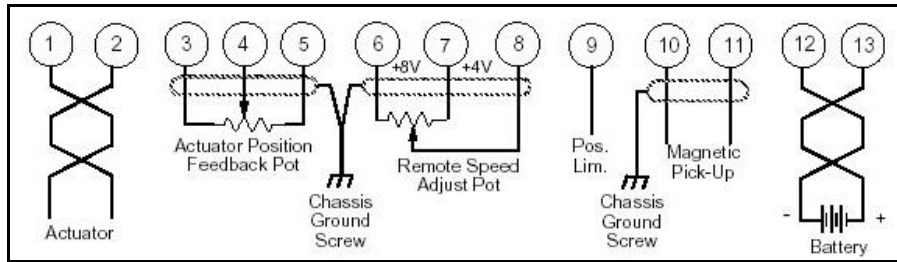

Dimensions

Dimensions in millimeters. Inches in brackets [].

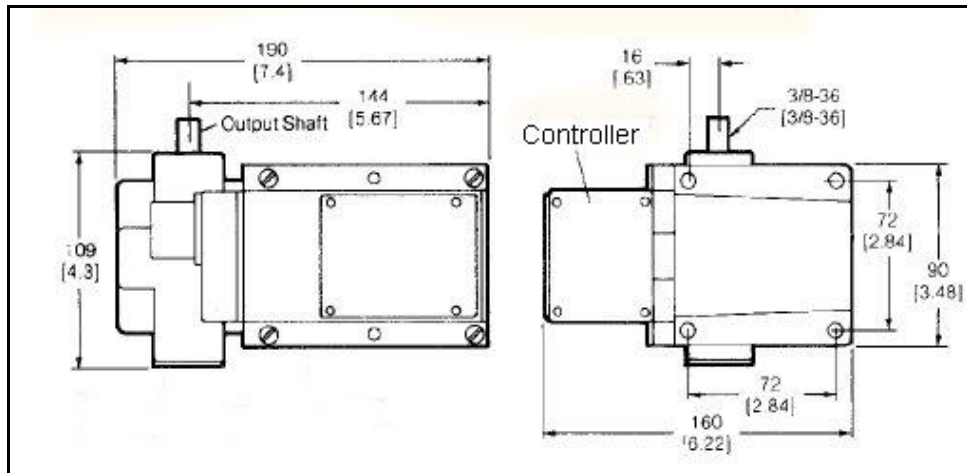

Standard Plus 1 Actuator / Clockwise Rotation

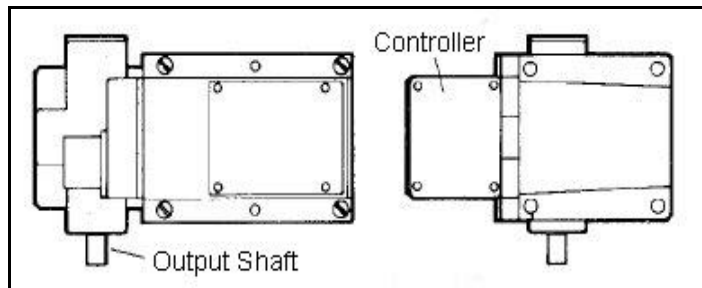

Standard Plus 1 Actuator / Counterclockwise Rotation

Dimensions (Cont'd.)

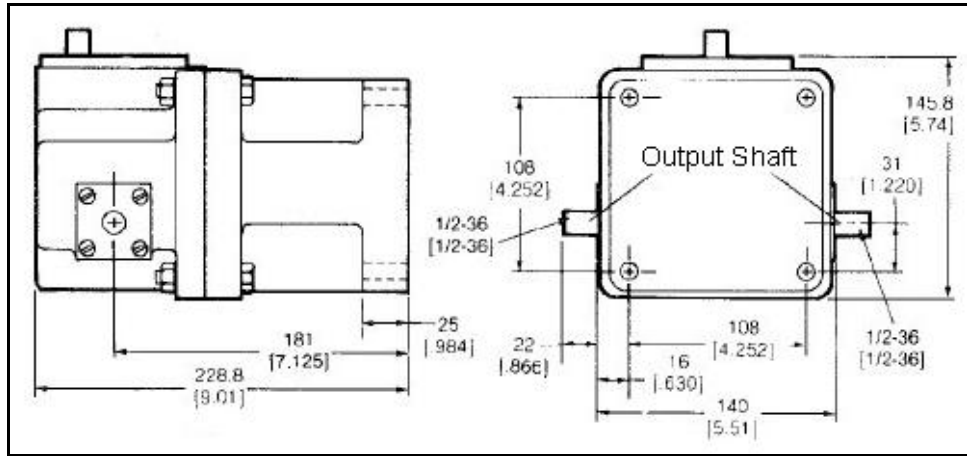

Plus 4 Actuator

Typical Installation Diagram

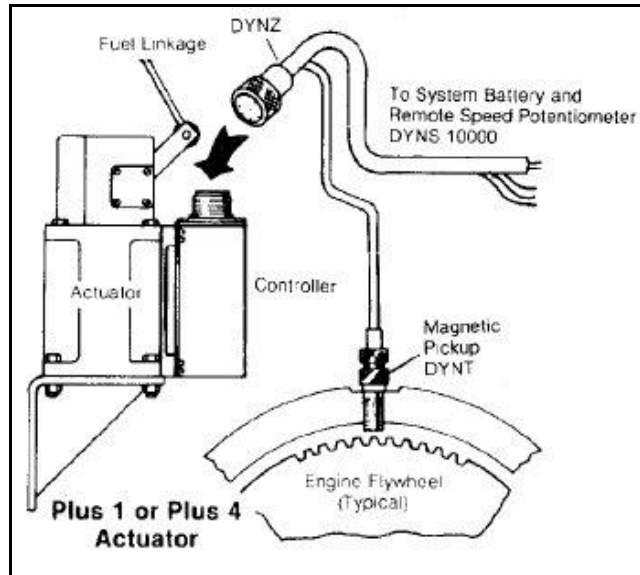

Typical Plus 1 or Plus 4 Basic Governor Wiring

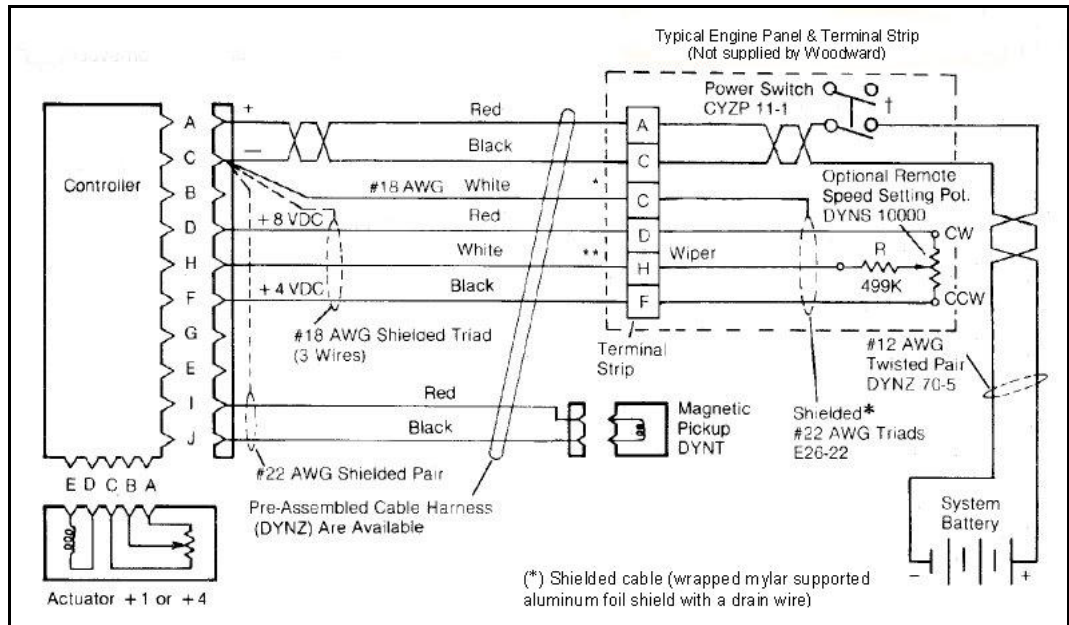

(*) White wire from Pin C must not be connected to same terminal as black wire from Pin C.

(†) Power switch wiring is shown for a negative ground system. When a positive ground system is being wired, the installer should switch (break) both the positive and negative leads.

(**) Wiring procedure when a remote speed setting potentiometer is not used.

If a terminal strip is not used, then isolate and tape the ends of the wires from Pins D, F and H to keep them from touching each other or other leads.

TABLE OF WIRE SIZES	
Size — AWG	Nominal mm
10	6
12	4
14	2.5
18	1.5
22	1.0

Plus 2 Wiring Diagrams

The available APECS panel mounted controllers and their input signal frequencies are noted below. Also listed are CE certified models.

Available in 12 or 24 Vdc.

Adjustments available: ACT, GAIN, DER, INT, LIM, DROOP, and SPEED (SPD)

Controller Part No.	Input Signal Frequency
Speed Controllers	
DYN1 10502-001	250 to 1200 Hz
DYN1 10503-001	1200 to 2500 Hz
DYN1 10504-001	2500 to 5000 Hz
DYN1 10506-001	5000 to 9500 Hz
CE Certified Controllers	
DYN1 10502-004	250 to 1200 Hz
DYN1 10503-004	1200 to 2500 Hz
DYN1 10504-004	2500 to 5000 Hz
DYN1 10506-004	5000 to 9500 Hz

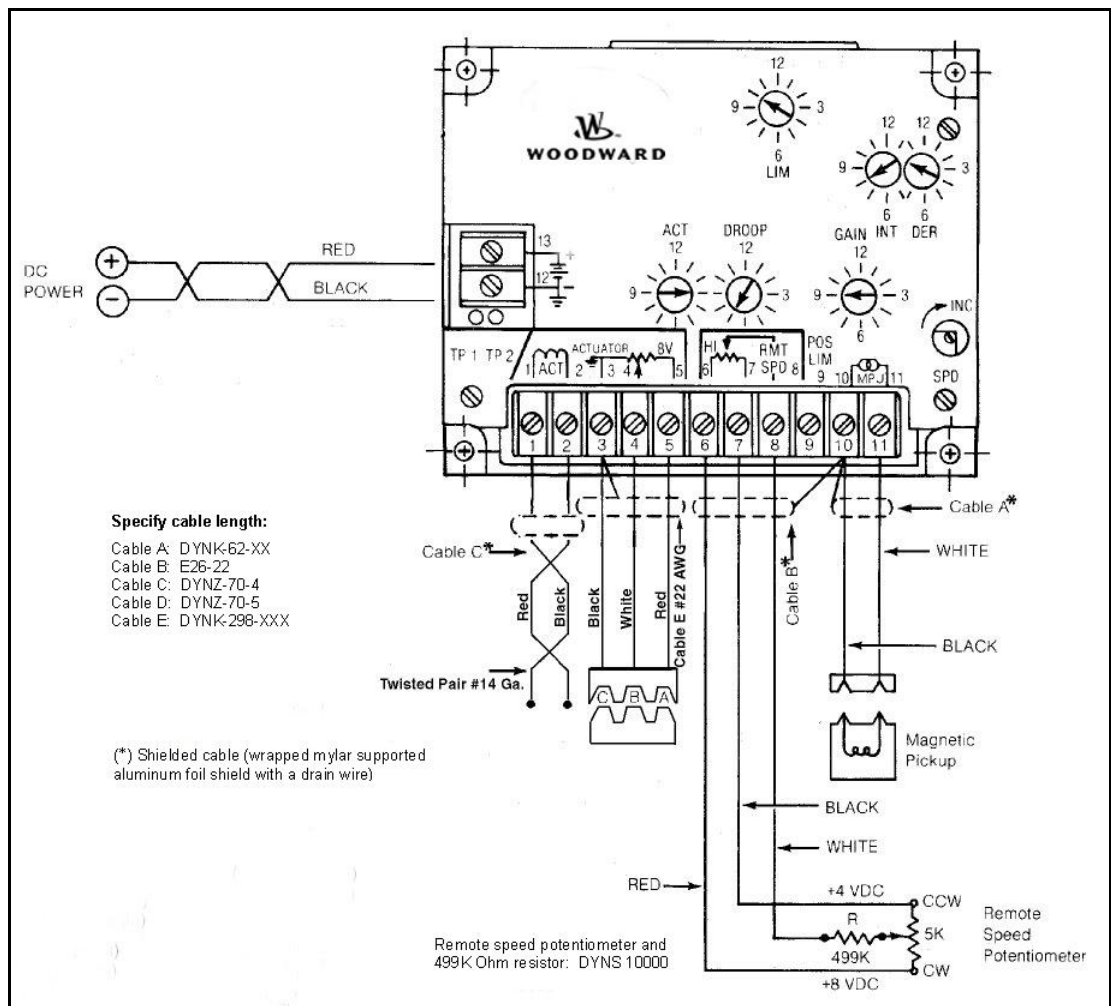

Wiring for CE Controllers

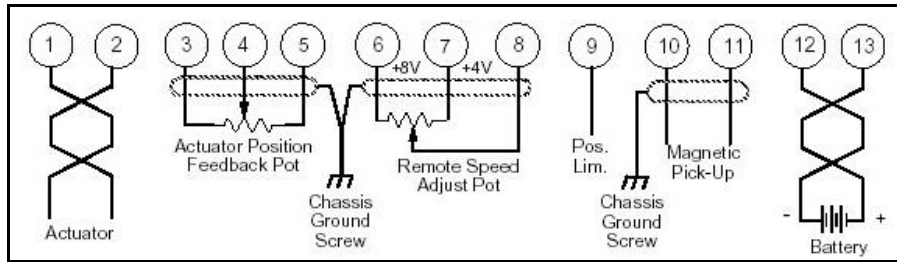

Dimensions

Dimensions in millimeters. Inches in brackets [].

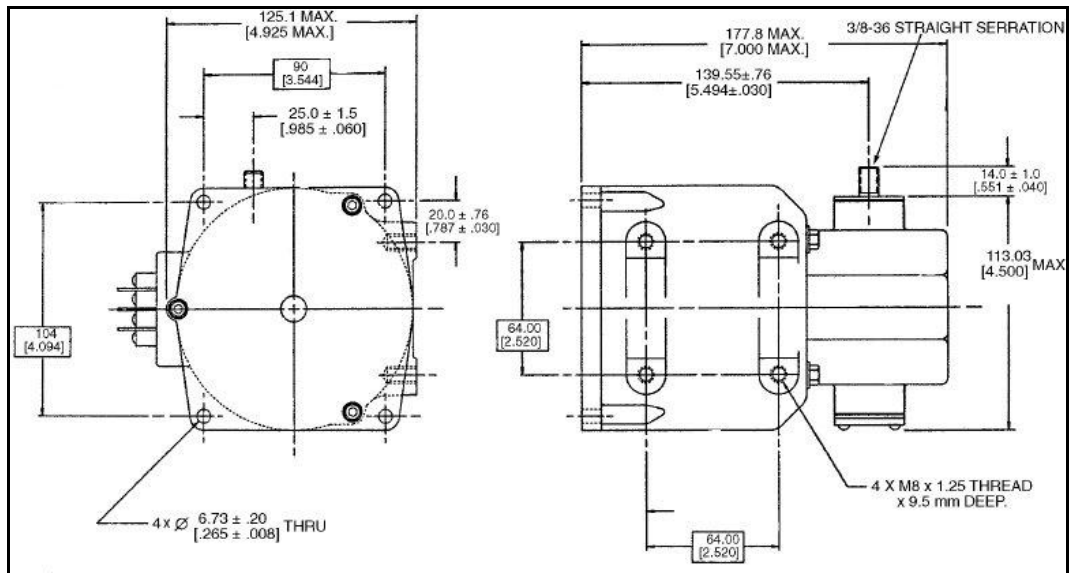

Typical Plus 2 Actuator Wiring

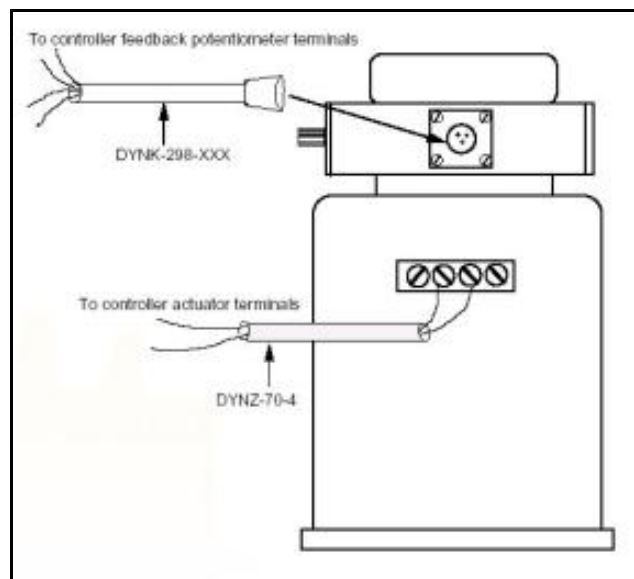

Plus 6 Wiring Diagrams

The following are standard actuators available for the Plus 6 governor.

DYNC 16000 Plus 6 with clockwise output shaft rotation

DYNC 16001 Plus 6 with counterclockwise output shaft rotation

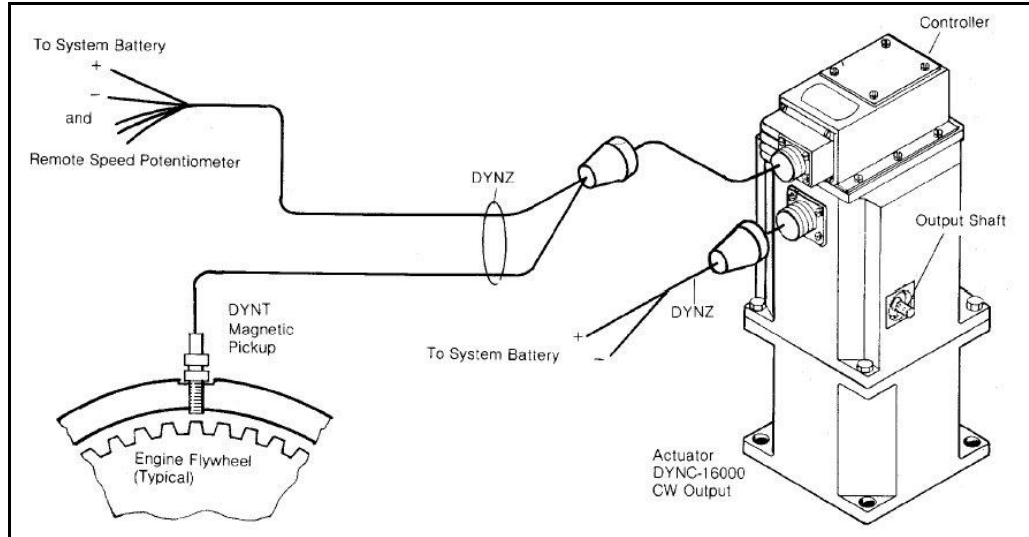

Typical Panel and Terminal Strip Wiring

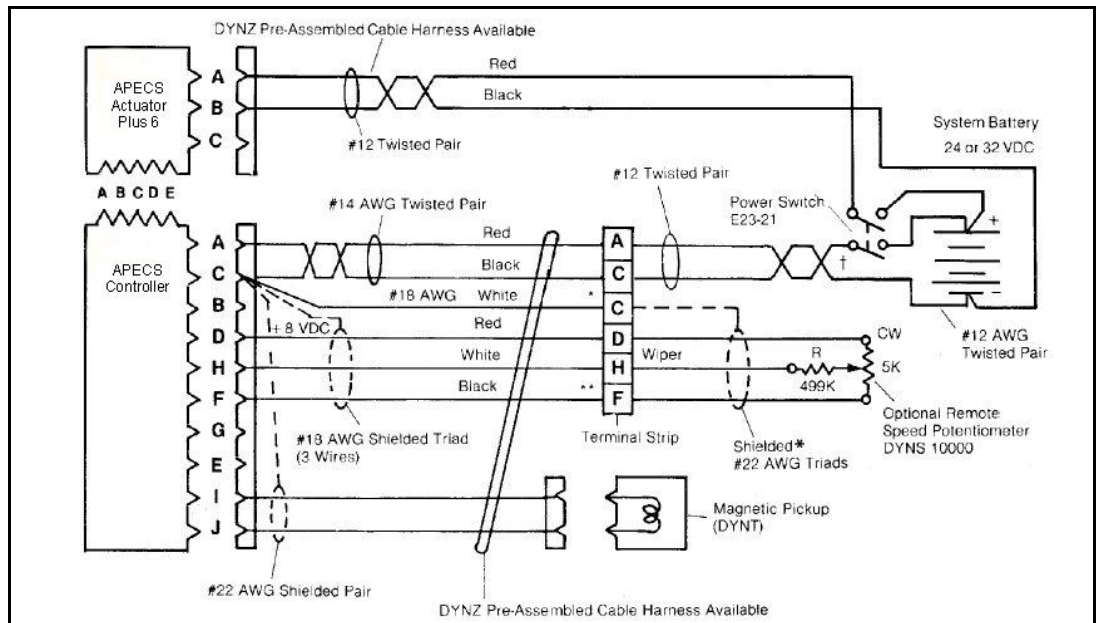

(*) White wire from Pin C must not be connected to same terminal as black wire from Pin C.

(†) Power switch wiring is shown for a negative ground system. When a positive ground system is being wired, the installer should switch (break) both the positive and negative leads.

(**) Wiring procedure when a remote speed setting potentiometer is not used.

If a terminal strip is not used, then isolate and tape the ends of the wires from Pins D, F and H to keep them from touching each other or other leads.

Typical Plus 6 Explosion Proof Governor Wiring

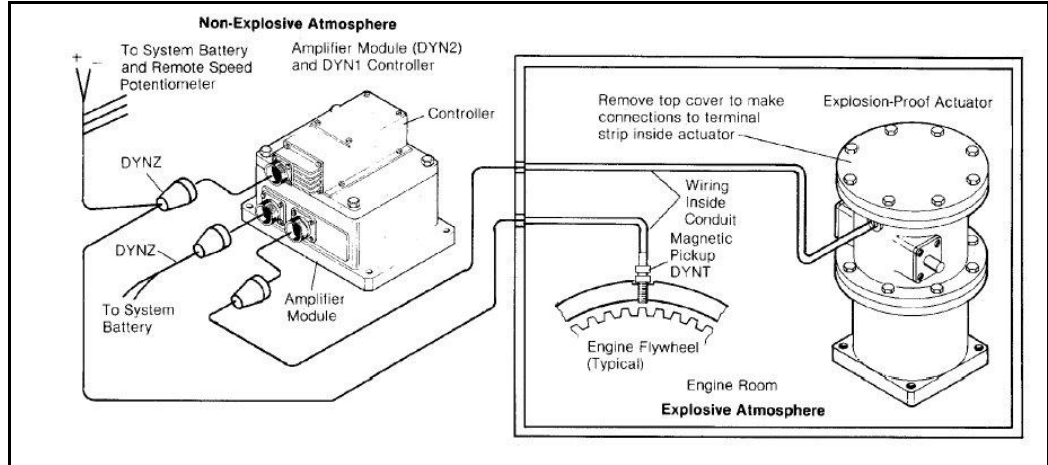

Typical Panel and Terminal Strip Wiring

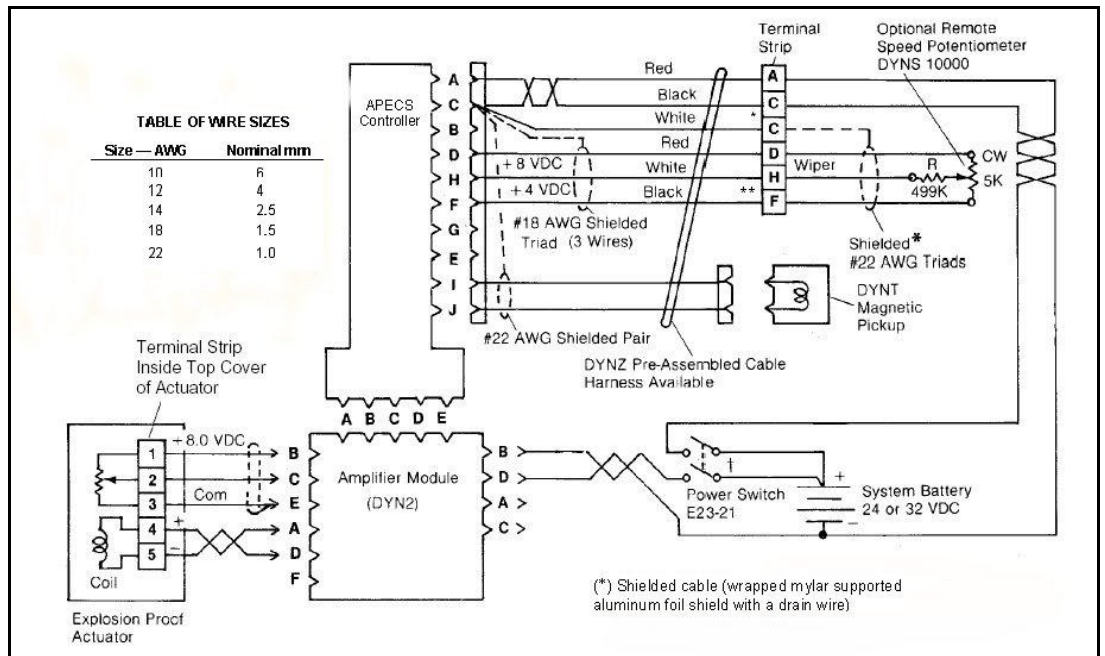

(*) White wire from Pin C must not be connected to same terminal as black wire from Pin C.

(†) Power switch wiring is shown for a negative ground system. When a positive ground system is being wired, the installer should switch (break) both the positive and negative leads.

(**) Wiring procedure when a remote speed setting potentiometer is not used.

If a terminal strip is not used, then isolate and tape the ends of the wires from Pins D, F and H to keep them from touching each other or other leads.

Chapter 4. Calibration and Adjustments

This chapter provides calibration information for the following APECS controllers:

DYN1-10002-002	DYN1-10502-001	☒ Certified Models:
DYN1-10003-002	DYN1-10503-001	DYN1-10502-004
DYN1-10004-002	DYN1-10504-001	DYN1-10503-004
DYN1-10006-002	DYN1-10506-001	DYN1-10505-004
		DYN1-10506-004

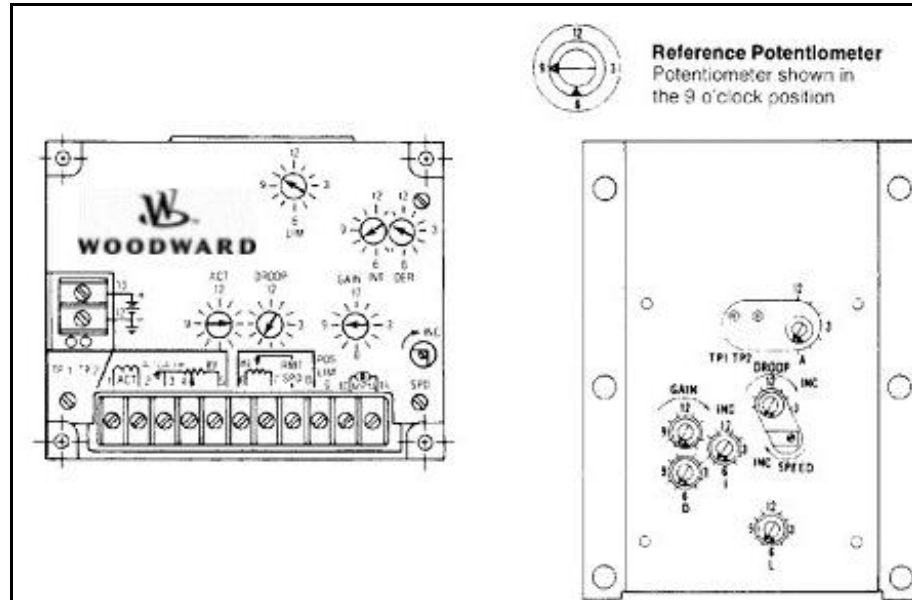

Figure 3—Electronic Control Box Adjustments Configurations

NOTE 1: Refer to Figure 3 as a reference guide before making any adjustments of “A (ACT)”, “D (DER)”, “DROOP”, “GAIN”, “I (INT)” or “L (LIM)” potentiometers.

1. Power “OFF” — engine not operating
 - a. Easier adjusting is possible by connecting an extension cable (Part No DYNZ-126) between control box and actuator.
 - b. Remove top cover from control box.

CAUTION

As a safety measure, the engine should be equipped with an independent overspeed shutdown device in the event of failure which may render the governor inoperative

2. Set potentiometers as indicated below:
 - a. Set “A (ACT)” at 3 o'clock.
 - b. Set “GAIN” at 9 o'clock.
 - c. Set “D (DER)” at 10 o'clock.
 - d. Set “I (INT)” at 8 o'clock.
 - e. “L (LIM)” is **factory adjusted** and should be about 10 o'clock. (See Note 4.)

3. For isochronous operation, set "DROOP" potentiometer fully counterclockwise (zero droop) and proceed to Step 4. **For droop operation, set "DROOP" potentiometer to desired droop.** Refer to Note 2.

NOTE 2: The amount of droop for a given setting depends on pick-up frequency and no load to full load actuator shaft rotation. A "DROOP" potentiometer setting of 9 o'clock will give about 3% droop, no load to full load, when the pick-up frequency is 4260 Hz and actuator shaft rotation is 13 from no load to full load. Lower pick-up frequency or smaller shaft rotation results in less droop.

4. If a remote speed potentiometer is used, set it to midrange.
5. **Start engine.** Then adjust controller "SPEED (SPD)" potentiometer until engine is operating at the desired speed (RPM). (**Clockwise** increases engine speed).
6. Adjust the "A (ACT)" potentiometer with engine **running** unloaded
 - a. Turn the "A (ACT)" potentiometer slowly clockwise until the actuator lever oscillates (jiggles) rapidly. Turn the "A (ACT)" potentiometer slowly counterclockwise until the rapid oscillation just stops.
 - b. Upset governor by tapping actuator lever. If the actuator lever oscillates rapidly, turn the "A (ACT)" potentiometer slowly counterclockwise until the rapid oscillation just stops.
7. If governor is unstable (hunting), turn "GAIN" potentiometer **slowly counterclockwise** until it is stable. (Moving actuator lever and constant engine speed means unit is governing and not hunting.) If governor is stable, turn "GAIN" potentiometer **slowly clockwise** until governor starts to hunt, then turn "GAIN" **slowly counterclockwise** until governor is stable. Upset governor by tapping actuator lever. Engine should return quickly to its commanded speed without hunting.
8. Turn "D (DER)" **clockwise** until actuator lever begins to hunt. One may have to upset governor by tapping actuator lever, then turn "D (DER)" **slowly counterclockwise** until engine is stable. ["D (DER)" setting may be fully clockwise on some engines which have large mass in the linkage.]

NOTE 3 Step 9 must be done when engine is unloaded.

9. After "GAIN", "A (ACT)" and "D (DER)" potentiometers are set, turn power switch "OFF". Let engine speed slow down to about half speed, and then turn power switch "ON". Watch or listen to engine speed. If engine speed overshoots commanded speed, turn "I (INT)" potentiometer a **small amount** counterclockwise. Keep repeating above until engine no longer overshoots its commanded speed. [If "L (LIM)" potentiometer is set too far clockwise, engine may also overshoot commanded speed.]
10. Changing the adjustments "A (ACT)", "D (DER)", "DROOP" and "GAIN" may cause a slight engine speed change which will require resetting the "SPEED" (SPD) adjustment.

11. **Changing droop potentiometer setting** adjustment of the “DROOP” potentiometer after the controller is calibrated [“A (ACT)” and “GAIN” settings set] may result in some instability when **large loads** are shed. Therefore, turning the “DROOP” potentiometer (clockwise) from a previous setting may cause system instability which can be improved (re-gained) by turning “A (ACT)” potentiometer (counterclockwise) slightly and turning “GAIN” potentiometer (clockwise) slightly.
12. If unit has a cover, place cover back onto controller to keep out dirt and moisture.

NOTE 4: Field Adjustment of “L (LIM)”: “L (LIM)” is factory adjusted and is sufficient for most installations. The following steps can be taken for setting the “L (LIM)” potentiometer to match the governor to the linkage on installations where the engine can be fully loaded (100%).

After “A (ACT)”, “GAIN”, “D (DER)” and “I (INT)” are adjusted, load engine to 100% (full load).

- (a) While observing frequency or RPM meter, turn “L (LIM)” potentiometer **slowly counterclockwise** until the frequency or RPM starts to decrease.
- (b) Turn “L (LIM)” potentiometer slowly clockwise until the frequency or RPM returns to the original value before “L (LIM)” was adjusted in Step (a) above.

Calibration and Adjustment Tips

If any of the following adjustments are not successful, reset the potentiometer to its original position before proceeding with calibration.

SYMPTON	POSSIBLE CAUSE	CORRECTIVE ACTION
Actuator lever oscillating (jig-gling) at a 10 to 15 Hz rate.	“A (ACT)” potentiometer set too far clockwise.	Turn “A (ACT)” slowly counterclockwise.
Actuator lever oscillating (hunting) at a 4 to 10 Hz rate.	“D (DER)” potentiometer set too far clockwise.	Turn “D (DER)” slowly counterclockwise.
Actuator lever oscillating (hunting) at a 2 to 3 Hz rate.	“GAIN” potentiometer set too far clockwise.	Turn “GAIN” slowly counterclockwise.
Actuator lever has a small amplitude oscillation of less than 1 Hz rate with no quick changes in position.	“I (INT)” potentiometer set too far clockwise.	Turn “I (INT)” slowly counterclockwise.

Adjustment Configurations

CONFIGURATION	CONTROL- LER*	INPUT SIGNAL FREQUENCY
Speed Controllers †		
A	DYN1 10002-2	250 to 1200 Hz
	DYN1 10003-2	1200 to 2500 Hz
	DYN1 10004-2	2500 to 5000 Hz
	DYN1 10002-6	5000 to 9500 Hz
Tandem Controller		
A	DYN1 10008-2	2500 to 5000 Hz
No Break Controller		
A	DYN1 10010	2500 to 5000 Hz
Propulsion Controllers ††		
B	DYN1 10024-2	250 to 1200 Hz
	DYN1 10025-2	1200 to 2500 Hz
	DYN1 10026-2	2500 to 5000 Hz

- (*) Available in 12, 24, or 32 Vdc
- (†) Adjustments available: A, Gain, D, I, L, Droop and Speed (under controller cover)
- (††) Adjustments available: A, Gain, D, I, Droop, High Limit, Low Limit and Speed (under controller cover).

Configuration A

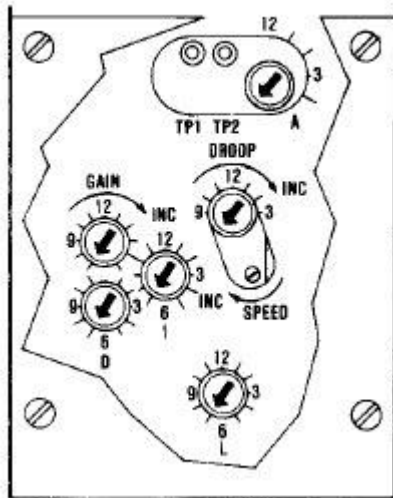

Configuration B

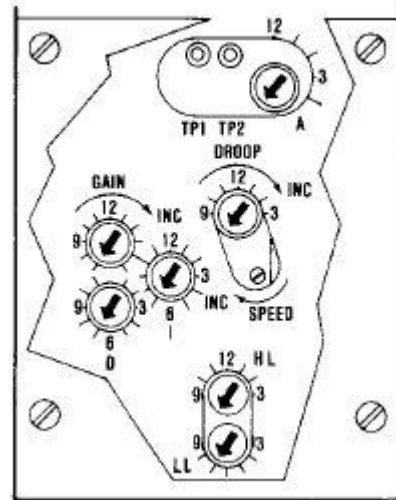

FOR REFERENCE ONLY: These controllers are no longer manufactured.

CONFIGURATION	CONTROL- LER*	INPUT SIGNAL FREQUENCY
Speed Controllers †		
C	DYN1 10112-0	250 to 1500 Hz
	DYN1 10113-0	1200 to 3000 Hz
	DYN1 10114-0	2500 to 6000 Hz
	DYN1 10116-0	5000 to 1000 Hz
Speed Controllers ††		
D	DYN1 10212-0	250 to 1500 Hz
	DYN1 10213-0	1200 to 3000 Hz
	DYN1 10214-0	2500 to 6000 Hz
	DYN1 10216-0	5000 to 1000 Hz
Wide Speed Range Controllers †††		
E	DYN1 10312-0	250 to 1500 Hz
	DYN1 10313-0	500 to 3000 Hz
	DYN1 10314-0	1000 to 6000 Hz
	DYN1 10316-0	2000 to 12000

- (†) Adjustments available: I, Droop and Speed (under controller cover)
Stability and Speed Trim (on side of controller)
- (††) Adjustments available: Gain, I, Droop and Speed (under controller cover).
- (†††) Adjustments available: Gain, D, I, Droop and Speed (under controller cover).

Configuration C

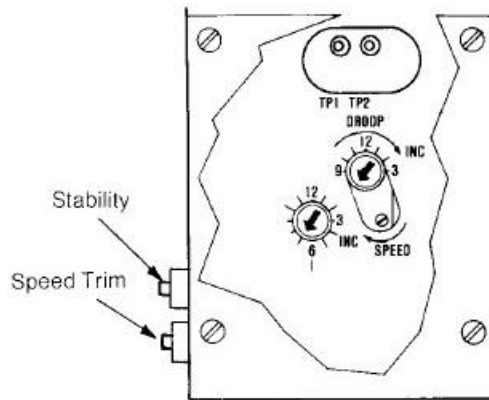

Configuration D

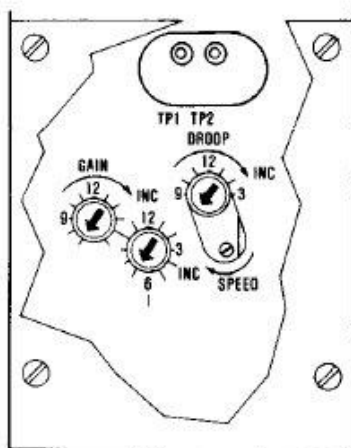

Configuration E

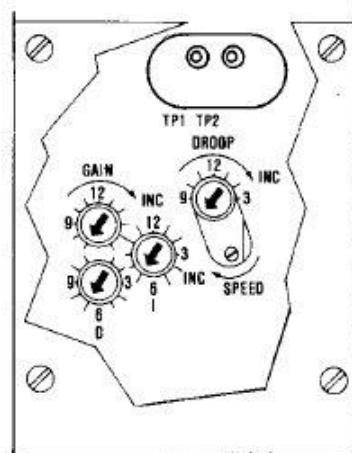

Chapter 5

Diagnostics & Troubleshooting

EVIDENCE OF FAILURE	POSSIBLE CAUSES	MEANS OF DETECTION	CORRECTIVE ACTION
	1 No DC power	Measure battery or power supply voltage.	Change battery or replace power supply.
		Disconnect 10 Pin connector from controller and measure DC voltage between Pin A & Pin C on cable connector with power switch "ON". Read battery voltage. (Pin A is positive with respect to Pin C) (Not applicable on 125 Vdc system)	Check wiring. a. Open lead to Pin A. b. Open lead to Pin C. c. Faulty power switch. d. Power leads not connected to power supply.
		Disconnect 3 Pin connector from actuator and measure DC voltage between Pin A & B on cable connector with power switch "ON".(This test is for +6 actuators only.)	Check wiring. a. Open lead to Pin A. b. Open lead to Pin B. c. Faulty power switch.
	2 Sticking linkage	Manually operate linkage to make sure it's not sticking.	Free up linkage.
3 Inadequate power supply voltage	Remove cover from controller. Place a jumper between TP1 & TP2. Turn power switch "ON" and measure the DC voltage between Pins A & C on the 10 Pin connector. (For +6 APECS actuators measure the DC voltage between Pins A & B on the actuator 3 Pin connector). Voltage should be 80% of nominal supply voltage for correct operation. Examples: 24 Vdc System: 24V x 0.80 = 19.2V 12 Vdc System: 12V x 0.80 = 9.6V 32 Vdc System: 32V x 0.80 = 25.6V	Larger supply. Larger leads from supply to controller. Check for poor or loose supply connections.	
Continued on next page . . .			

EVIDENCE OF FAILURE	POSSIBLE CAUSES	MEANS OF DETECTION	CORRECTIVE ACTION
	<p>4 No signal or weak signal from magnetic pickup</p>	<p>Disconnect 10 Pin connector from controller. Measure the AC voltage between Pin I & J on cable connector while cranking engine. Meter must read 2.5 V or greater during cranking.</p> <p>(AC input impedance of meter must be 5000 ohms / volt or greater.)</p> <p>Check the following:</p> <ul style="list-style-type: none"> • Pickup resistance (200 ohms) • Magnetic pickup leads (Pins A & B) must be isolated from case • Loose connector • Mechanical integrity (May be damaged pole piece. Flywheel may have run out.) • Water in connector • Broken leads • Shorted leads • Shield drain wire (isolated from gnd) • Gap — .015 – .005" (0.37 – 0.127 mm) <p>NOTE: One complete turn of the pickup is approx. 0.0555".</p>	<p>Check leads I & J from 10 Pin cable connector to magnetic pickup for continuity.</p> <p>Check for correct installation of magnetic pickup.</p> <p>Replace magnetic pickup if unable to obtain an output signal from unit.</p>
	<p>5 Short in either male or female member (10 Pin connector) between Pins C to D; C to H; C to E; C to J; C to G</p>	<p>Turn "OFF" power switch. Disconnect 10 Pin connector.</p> <p>Check cable connector for short(s) between C & D, C & E, C & G, C & H</p> <p>Check cable connector for short(s) between C & D, C & E, C & G, C & H</p>	<p>Check connector and leads for cause of short(s). Repair or replace.</p> <p>Replace controller.</p>
	<p>6 Actuator failure</p>	<p>Try different actuator</p> <p>Remove controller from actuator and perform the following measurements:</p> <p>(1) Measure resistance between actuator case and pins on the actuator connectors. These measurements will all indicate an open circuit on a good actuator.</p>	<p>Replace controller.</p> <p>If a short or resistance path is indicated, replace actuator.</p>

	6 Actuator failure (Cont'd.)	(2) Measure resistance between Pins D & E on actuator connector. If an open circuit is indicated it means the actuator coil is open and the unit is faulty. (This test is for Plus 1 actuator only).	Replace actuator.
		(3) Measure for shorts between Pins A to C or B to C on actuator 5 Pin connector. (A good actuator should not indicate a short circuit A to C or B to C.)	Replace actuator.
	CONTROLLER SHOULD BE CHECKED AT THIS TIME BECAUSE IT IS DISCONNECTED FROM ACTUATOR.	(4) Measure for shorts between Pins A to C on actuator 5 Pin connector. (A good actuator will measure 4,000 to 20,000 ohms.) An open lead to Pin A on actuator connector will cause unit to go to minimum fuel position.	Replace actuator.
		(5) Measure for shorts between Pins A to C or B to C on controller 5 Pin connector. (A good controller should not indicate a short circuit A to C or B to C.)	Replace controller.
7 Controller failure	With power switch "ON", measure DC voltage between Pin C (-) and Pin D (+) at the controller 10 Pin connector. This voltage should be +8.0V – 0.5 V. .	Replace controller.	

EVIDENCE OF FAILURE	POSSIBLE CAUSES	MEANS OF DETECTION	CORRECTIVE ACTION
Actuator lever to full fuel position each time power switch is turn "ON". (Engine not operating.)	1 Magnetic pickup leads not properly shielded	Check for open shield lead on magnetic pickup. See wiring diagrams in Chapter 3 for correct shielding.	Correct the wiring. The magnetic pickup shield must be tied to the controller Pin C. The other end of shield must not be tied to anything.
	2 Short between Pins B & C or C & F in either male or female member (10 Pin connector).	Turn "OFF" power switch. Disconnect 10 Pin connector and perform following checks: Check cable connector for short(s) between C & B or C & F.	Check connector and leads for cause of short(s). Repair or replace.
		Check box connector for short(s) between C & B or C & F.	Replace controller.

EVIDENCE OF FAILURE	POSSIBLE CAUSES	MEANS OF DETECTION	CORRECTIVE ACTION
<p>Actuator lever to full fuel position each time power switch is turn "ON". (Engine not operating.)</p>	<p>3 Actuator failure</p>	<p>Try another actuator. Measure for open between Pins A to C on the actuator 5 Pin connector. (A good actuator will measure 4,000 ohms to 20,000 ohms.) Open lead to Pin C on actuator will cause unit to go to maximum fuel position.</p>	<p>Replace actuator.</p>
	<p>4 Controller failure</p>	<p>Try another controller. Make resistance check between Pins E and C on the controller 5 Pin connector. Controller must be removed from actuator. A good controller will measure approximately 360 ohms – 20% when the plus lead of meter is connected to Pin C and minus lead is connected to Pin E. Reversing the meter leads, minus to Pin C and plus to Pin E will measure (infinity) open circuit.</p>	<p>Replace controller. Replace controller if a short circuit was detected between Pins E and C. Replace controller if an open circuit was detected between Pins E and C with meter leads connected in both directions.</p>
	<p>5 Amplifier module failure (Used on explosion proof actuator)</p>	<p>Try another amplifier module.</p>	<p>Replace amplifier module.</p>
<p>Erratic governor operation</p>	<p>1 Poor electrical connection between supply voltage and controller</p>	<p>Measure voltage Pin A and C on the 10 Pin connector while engine is operational. Read nominal battery voltage.</p>	<p>Correct wiring.</p>
	<p>2 Poor electrical connection between supply voltage and Plus 6 actuator</p>	<p>Measure voltage Pin A and B on the 3 Pin connector.</p>	<p>Correct wiring.</p>
	<p>3 Low battery supply voltage at controller</p>	<p>Same as above</p>	<p>Charge battery.</p>
	<p>4 Electrical noise (RFI) pickup due to poor shielding</p>	<p>Observe output shaft (lever) on actuator. It will make a quick correction of fuel throttle position without a change in load.</p>	<p>Check for correct shielding.</p>
	<p>5 Electrical noise (RFI) fed through power supply</p>	<p>Observe output shaft (lever) on actuator. It will make a quick correction of fuel throttle position without a change in load.</p>	<p>Check all wiring connections in system.</p>

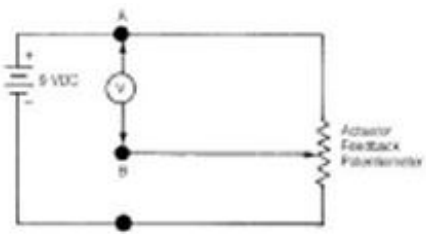
EVIDENCE OF FAILURE	POSSIBLE CAUSES	MEANS OF DETECTION	CORRECTIVE ACTION
	<p>6 Defective feedback potentiometer in actuator</p>	<p>Check the feedback potentiometer with a 9 Vdc transistor battery.</p>	<p>Remove control box from actuator.</p> <ol style="list-style-type: none"> 1. Connect the plus of the 9 Vdc battery to Pin A, and the minus to Pin C of the 5 Pin connector. Refer to drawing. 2. Connect the plus lead of the volt meter to Pin A, and the minus lead to Pin B. 3. Using a standard lever, slowly rotate the actuator output shaft to maximum while observing the volt meter. <p>NOTE: The voltage will be at approximately 4.0 Vdc initially and will increase to approximately 4.5 Vdc at full stroke of the actuator. (If the voltage change is not evident or is erratic, replace actuator.)</p>
	<p>A, B, and C of 5 Pin Actuator Connector</p> 		
<p>Slow small amplitude hunting of engine RPM or generator frequency</p>	<p>1 Sticking linkage or very loose linkage</p>	<p>Fairly regular but quick changes in position of fuel rack and then it rests and moves back to original position</p>	<p>Correct linkage arrangement.</p>
	<p>2 Sticking injector(s) in fuel system pump</p>	<p>Same as above</p>	<p>Correct fuel system.</p>
	<p>3 APECS actuator (internal) problem</p>	<p>Change actuator</p>	<p>Replace actuator.</p>
<p>Engine won't start. (Actuator lever goes to full fuel position each time engine is cranked.)</p>	<p>Fuel not getting to engine</p>	<p>Try to operate engine manually.</p>	<p>Check fuel line. Check safety shutdowns.</p>

EVIDENCE OF FAILURE	POSSIBLE CAUSES	MEANS OF DETECTION	CORRECTIVE ACTION
<p>Actuator lever oscillating (hunting). (If any of these adjustments are not successful, reset potentiometer to its original position before continuing with the troubleshooting.)</p>	<p>“A” pot set too far clockwise</p> <p>“D” pot set too far clockwise</p> <p>“GAIN” set too far clockwise</p> <p>“I” pot set too far clockwise</p>	<p>Acutator lever oscillating (jiggling) at a 10 to 15 Hz rate.</p> <p>Acutator lever oscillating (hunting) at a 4 to 10 Hz rate.</p> <p>Acutator lever oscillating (hunting) at a 2 to 3 Hz rate.</p> <p>Actuator lever has a small amplitude oscillation of approx 1 Hz with no quick changes in position.</p>	<p>Turn “A” slowly counterclockwise.</p> <p>Turn “D” slowly counterclockwise.</p> <p>Turn “GAIN” slowly counterclockwise.</p> <p>Turn “I” slowly counterclockwise.</p>
<p>Remote potentiometer adjustment has no effect on setting engine RPM</p>	<p>Open circuit to Pins D, F, or H in either male or female member of controller (10 Pin connector).</p>	<p>1. Turn “OFF” power switch. Disconnect 10 Pin connector.</p> <p>(a) Check cable connector for open circuit between Pins D & F, Pins D & H, and Pins F & H.</p> <p>(b) If external wiring and remote potentiometer check out correctly, change controller.</p> <p>2..Check out the following points at the remote potentiometer:</p> <ul style="list-style-type: none"> • Mechanical check • Resistance check • Wiring • Speed range resistor • Drain shield (cut off and isolate from ground and other leads) • Voltage check for 4 and 8 Vdc at the remote potentiometer 	<p>Check connector, remote potentiometer and leads for cause of open circuit(s). Repair or replace faulty components.</p> <p>Replace controller.</p> <p>Repair or replace faulty components.</p>
<p>Engine operates above set speed. (May overspeed)</p>	<p>Faulty actuator:</p> <p>Short between Pins A & B of the 5 Pin actuator connector.</p> <p>Open lead to Pin C of 5 Pin actuator connector.</p>	<p>Remote controller from actuator.</p> <p>Measure for short(s) between Pin A & B on the actuator 5 Pin connector.</p> <p>Measure for open circuit by measuring between Pins B & C on 5 Pin connector.</p>	<p>Replace actuator.</p> <p>Replace actuator.</p>

Chapter 8.

Service Options

Product Service Options

The following factory options are available for servicing Woodward equipment, based on the standard Woodward Product and Service Warranty (5-01-1205) that is in effect at the time the product is purchased from Woodward or the service is performed:

- Replacement/Exchange (24-hour service)
- Flat Rate Repair
- Flat Rate Remanufacture

If you are experiencing problems with installation or unsatisfactory performance of an installed system, the following options are available:

- Consult the troubleshooting guide in the manual.
- Contact Woodward technical assistance (see “How to Contact Woodward” later in this chapter) and discuss your problem. In most cases, your problem can be resolved over the phone. If not, you can select which course of action you wish to pursue based on the available services listed in this section.

Replacement/Exchange

Replacement/Exchange is a premium program designed for the user who is in need of immediate service. It allows you to request and receive a like-new replacement unit in minimum time (usually within 24 hours of the request), providing a suitable unit is available at the time of the request, thereby minimizing costly downtime. This is also a flat rate structured program and includes the full standard Woodward product warranty (Woodward Product and Service Warranty 5-01-1205).

This option allows you to call in the event of an unexpected outage, or in advance of a scheduled outage, to request a replacement control unit. If the unit is available at the time of the call, it can usually be shipped out within 24 hours. You replace your field control unit with the like-new replacement and return the field unit to the Woodward facility as explained below (see “Returning Equipment for Repair” later in this chapter).

Charges for the Replacement/Exchange service are based on a flat rate plus shipping expenses. You are invoiced the flat rate replacement/exchange charge plus a core charge at the time the replacement unit is shipped. If the core (field unit) is returned to Woodward within 60 days, Woodward will issue a credit for the core charge. [The core charge is the average difference between the flat rate replacement/exchange charge and the current list price of a new unit.]

Return Shipment Authorization Label. To ensure prompt receipt of the core, and avoid additional charges, the package must be properly marked. A return authorization label is included with every Replacement/Exchange unit that leaves Woodward. The core should be repackaged and the return authorization label affixed to the outside of the package. Without the authorization label, receipt of the returned core could be delayed and cause additional charges to be applied.

Flat Rate Repair

Flat Rate Repair is available for the majority of standard products in the field. This program offers you repair service for your products with the advantage of knowing in advance what the cost will be. All repair work carries the standard Woodward service warranty (Woodward Product and Service Warranty 5-01-1205) on replaced parts and labor.

Flat Rate Remanufacture

Flat Rate Remanufacture is very similar to the Flat Rate Repair option with the exception that the unit will be returned to you in “like-new” condition and carry with it the full standard Woodward product warranty (Woodward Product and Service Warranty 5-01-1205). This option is applicable to mechanical products only.

Returning Equipment for Repair

If a control (or any part of an electronic control) is to be returned to Woodward for repair, please contact Woodward in advance to obtain a Return Authorization Number. When shipping the item(s), attach a tag with the following information:

- name and location where the control is installed;
- name and phone number of contact person;
- complete Woodward part number(s) and serial number(s);
- description of the problem;
- instructions describing the desired type of repair.



CAUTION

To prevent damage to electronic components caused by improper handling, read and observe the precautions in Woodward manual 82715, *Guide for Handling and Protection of Electronic Controls, Printed Circuit Boards, and Modules*.

Packing a Control

Use the following materials when returning a complete control:

- protective caps on any connectors;
- antistatic protective bags on all electronic modules;
- packing materials that will not damage the surface of the unit;
- at least 4 inches (100 mm) of tightly packed, industry-approved packing material;
- a packing carton with double walls;
- a strong tape around the outside of the carton for increased strength.

Return Authorization Number

When returning equipment to Woodward, please telephone and ask for the Customer Service Department [1 (800) 523-2831 in North America or +1 (970) 482-5811]. They will help expedite the processing of your order through our distributors or local service facility. To expedite the repair process, contact Woodward in advance to obtain a Return Authorization Number, and arrange for issue of a purchase order for the item(s) to be repaired. No work can be started until a purchase order is received.



NOTE

We highly recommend that you make arrangement in advance for return shipments. Contact a Woodward customer service representative at 1 (800) 523-2831 in North America or +1 (970) 482-5811 for instructions and for a Return Authorization Number.

Replacement Parts

When ordering replacement parts for controls, include the following information:

- the part number(s) (XXXX-XXXX) that is on the enclosure nameplate;
- the unit serial number, which is also on the nameplate.

How to Contact Woodward

In North America use the following address when shipping or corresponding:

Woodward Governor Company
 PO Box 1519
 1000 East Drake Rd
 Fort Collins CO 80522-1519, USA

Telephone—+1 (970) 482-5811 (24 hours a day)
 Toll-free Phone (in North America)—1 (800) 523-2831
 Fax—+1 (970) 498-3058

For assistance outside North America, call one of the following international Woodward facilities to obtain the address and phone number of the facility nearest your location where you will be able to get information and service.

<u>Facility</u>	<u>Phone Number</u>
Brazil	+55 (19) 3708 4800
India	+91 (129) 230 7111
Japan	+81 (476) 93-4661
The Netherlands	+31 (23) 5661111

You can also contact the Woodward Customer Service Department or consult our worldwide directory on Woodward's website (www.woodward.com) for the name of your nearest Woodward distributor or service facility. [For worldwide directory information, go to www.woodward.com/ic/locations.]

Engineering Services

Woodward Industrial Controls Engineering Services offers the following after-sales support for Woodward products. For these services, you can contact us by telephone, by email, or through the Woodward website.

- Technical Support
- Product Training
- Field Service

Contact information:

Telephone—+1 (970) 482-5811

Toll-free Phone (in North America)—1 (800) 523-2831

Email—icinfo@woodward.com

Website—www.woodward.com/ic

Technical Support is available through our many worldwide locations or our authorized distributors, depending upon the product. This service can assist you with technical questions or problem solving during normal business hours. Emergency assistance is also available during non-business hours by phoning our toll-free number and stating the urgency of your problem. For technical support, please contact us via telephone, email us, or use our website and reference **Customer Services** and then **Technical Support**.

Product Training is available at many of our worldwide locations (standard classes). We also offer customized classes, which can be tailored to your needs and can be held at one of our locations or at your site. This training, conducted by experienced personnel, will assure that you will be able to maintain system reliability and availability. For information concerning training, please contact us via telephone, email us, or use our website and reference **Customer Services** and then **Product Training**.

Field Service engineering on-site support is available, depending on the product and location, from one of our many worldwide locations or from one of our authorized distributors. The field engineers are experienced both on Woodward products as well as on much of the non-Woodward equipment with which our products interface. For field service engineering assistance, please contact us via telephone, email us, or use our website and reference **Customer Services** and then **Technical Support**.

Technical Assistance

If you need to telephone for technical assistance, you will need to provide the following information. Please write it down here before phoning:

General

Your Name _____

Site Location _____

Phone Number _____

Fax Number _____

Prime Mover Information

Engine/Turbine Model Number _____

Manufacturer _____

Number of Cylinders (if applicable) _____

Type of Fuel (gas, gaseous, steam, etc) _____

Rating _____

Application _____

Control/Governor Information

Please list all Woodward governors, actuators, and electronic controls in your system:

Woodward Part Number and Revision Letter

Control Description or Governor Type _____

Serial Number _____

Woodward Part Number and Revision Letter

Control Description or Governor Type _____

Serial Number _____

Woodward Part Number and Revision Letter

Control Description or Governor Type _____

Serial Number _____

If you have an electronic or programmable control, please have the adjustment setting positions or the menu settings written down and with you at the time of the call.

We appreciate your comments about the content of our publications.

Send comments to: icinfo@woodward.com

Please include the manual number from the front cover of this publication.



PO Box 1519, Fort Collins CO 80522-1519, USA
1000 East Drake Road, Fort Collins CO 80525, USA
Phone +1 (970) 482-5811 • Fax +1 (970) 498-3058

Email and Website—www.woodward.com



FM 57982
BS EN ISO 9001:1994
6 March 2001

Woodward has company-owned plants, subsidiaries, and branches,
as well as authorized distributors and other authorized service and sales facilities
throughout the world.

Complete address / phone / fax / email information for all locations is available on
our website.