



Installation and Operation Manual



EPG Electrically Powered Governor

**Isochronous Models 512/524 and 1712/1724
Standard, Start Fuel Limit, Dual Dynamics
UL Listed E97763**

Manual 82493 (Revision R)

WARNING—DANGER OF DEATH OR PERSONAL INJURY



WARNING—FOLLOW INSTRUCTIONS

Read this entire manual and all other publications pertaining to the work to be performed before installing, operating, or servicing this equipment. Practice all plant and safety instructions and precautions. Failure to follow instructions can cause personal injury and/or property damage.



WARNING—OUT-OF-DATE PUBLICATION

This publication may have been revised or updated since this copy was produced. To verify that you have the latest revision, be sure to check the Woodward website:

www.woodward.com/pubs/current.pdf

The revision level is shown at the bottom of the front cover after the publication number. The latest version of most publications is available at:

www.woodward.com/publications

If your publication is not there, please contact your customer service representative to get the latest copy.



WARNING—OVERSPEED PROTECTION

The engine, turbine, or other type of prime mover should be equipped with an overspeed shutdown device to protect against runaway or damage to the prime mover with possible personal injury, loss of life, or property damage.

The overspeed shutdown device must be totally independent of the prime mover control system. An overtemperature or overpressure shutdown device may also be needed for safety, as appropriate.



WARNING—PROPER USE

Any unauthorized modifications to or use of this equipment outside its specified mechanical, electrical, or other operating limits may cause personal injury and/or property damage, including damage to the equipment. Any such unauthorized modifications: (i) constitute "misuse" and/or "negligence" within the meaning of the product warranty thereby excluding warranty coverage for any resulting damage, and (ii) invalidate product certifications or listings.

CAUTION—POSSIBLE DAMAGE TO EQUIPMENT OR PROPERTY



CAUTION—BATTERY CHARGING

To prevent damage to a control system that uses an alternator or battery-charging device, make sure the charging device is turned off before disconnecting the battery from the system.



CAUTION—ELECTROSTATIC DISCHARGE

Electronic controls contain static-sensitive parts. Observe the following precautions to prevent damage to these parts.

- Discharge body static before handling the control (with power to the control turned off, contact a grounded surface and maintain contact while handling the control).
- Avoid all plastic, vinyl, and Styrofoam (except antistatic versions) around printed circuit boards.
- Do not touch the components or conductors on a printed circuit board with your hands or with conductive devices.

IMPORTANT DEFINITIONS

- A **WARNING** indicates a potentially hazardous situation which, if not avoided, could result in death or serious injury.
- A **CAUTION** indicates a potentially hazardous situation which, if not avoided, could result in damage to equipment or property.
- A **NOTE** provides other helpful information that does not fall under the warning or caution categories.

Revisions—Text changes are indicated by a black line alongside the text.

Woodward Governor Company reserves the right to update any portion of this publication at any time. Information provided by Woodward Governor Company is believed to be correct and reliable. However, no responsibility is assumed by Woodward Governor Company unless otherwise expressly undertaken.

© Woodward 1983
All Rights Reserved

Contents

ELECTROSTATIC DISCHARGE AWARENESS	II
CHAPTER 1. GENERAL INFORMATION.....	1
Introduction.....	1
Application	1
Part Number Selection	1
Accessories	3
References	3
CHAPTER 2. INSTALLATION, CHECKOUT, AND CALIBRATION.....	6
General.....	6
Speed Control Mounting.....	6
Actuator Mounting and Linkage.....	6
Wiring Instructions	8
Installation Checks	13
CHAPTER 3. OPERATION	18
CHAPTER 4. DESCRIPTION.....	19
Speed Control Applications	19
Applications Using a Ramp Generator.....	21
Paralleled Generator Applications.....	21
CHAPTER 5. TROUBLESHOOTING.....	23
Troubleshooting Procedure	23
Other Checks.....	23
CHAPTER 6. SERVICE OPTIONS	25
Product Service Options.....	25
Returning Equipment for Repair.....	26
Replacement Parts	27
How to Contact Woodward.....	27
Engineering Services	28
Technical Assistance.....	29
DECLARATIONS	31

Illustrations and Tables

Figure 1-1. Basic Electrically Powered Governor System	4
Figure 1-2. Outline Drawing for EPG 512/1712 and 524/1724 Speed Controls	5
Figure 1-3. Outline Drawing for EPG 1712/1724 and 512/524 Actuators.....	5
Figure 2-1. Typical Installation Kit	6
Figure 2-2. Linear Linkage	7
Figure 2-3. Carburetor Compensating Linkage at Minimum Fuel.....	7
Figure 2-4. Carburetor Compensating Linkage at Maximum Fuel.....	7
Figure 2-5. Typical EPG (Isochronous) Wiring Diagram	9
Figure 2-6. Correct and Incorrect Wiring to Battery	10
Figure 2-7. Typical Wiring to 2500 Ramp Generator	11
Figure 2-8. Additional Wiring to Install the EPG Load Sensor	12
Figure 2-9. Starting and Transient Response Curves.....	17
Figure 4-1. EPG Block Schematic Diagram	20
Figure 4-2. Actuator Schematic.....	21
Table 1-1. Part Number Selection Table	2

Electrostatic Discharge Awareness

All electronic equipment is static-sensitive, some components more than others. To protect these components from static damage, you must take special precautions to minimize or eliminate electrostatic discharges.

Follow these precautions when working with or near the control.

1. Before doing maintenance on the electronic control, discharge the static electricity on your body to ground by touching and holding a grounded metal object (pipes, cabinets, equipment, etc.).
2. Avoid the build-up of static electricity on your body by not wearing clothing made of synthetic materials. Wear cotton or cotton-blend materials as much as possible because these do not store static electric charges as much as synthetics.
3. Keep plastic, vinyl, and Styrofoam materials (such as plastic or Styrofoam cups, cup holders, cigarette packages, cellophane wrappers, vinyl books or folders, plastic bottles, and plastic ash trays) away from the control, the modules, and the work area as much as possible.
4. Do not remove the printed circuit board (PCB) from the control cabinet unless absolutely necessary. If you must remove the PCB from the control cabinet, follow these precautions:
 - Do not touch any part of the PCB except the edges.
 - Do not touch the electrical conductors, the connectors, or the components with conductive devices or with your hands.
 - When replacing a PCB, keep the new PCB in the plastic antistatic protective bag it comes in until you are ready to install it. Immediately after removing the old PCB from the control cabinet, place it in the antistatic protective bag.



CAUTION—ELECTROSTATIC DISCHARGE

To prevent damage to electronic components caused by improper handling, read and observe the precautions in Woodward manual 82715, *Guide for Handling and Protection of Electronic Controls, Printed Circuit Boards, and Modules*.

Chapter 1.

General Information

Introduction

This manual covers Electrically Power Governor (EPG) models 512/524 and 1712/1724. Refer to the appropriate manual or contact Woodward for information about other versions of the EPG.

Application

The EPG is used to control the speed of diesel, gas, and gasoline engines. It can also control the speed of gas turbines. Installation of EPG actuators is simple because they require neither mechanical drive nor hydraulic supply.

The EPG handles prime movers with mechanical loads and generator loads equally well. Generator sets which will be paralleled, however, require additional appropriate switch gear, current and potential transformers, and the Woodward Generator Load Sensor.

An EPG is a three-component system, requiring a magnetic pickup, speed control, and actuator.

A battery charger must be used to keep the battery charged. Maximum steady state current consumption is 4 A for the 12-volt models (512/1712), and 3 A for the 24-volt models (524/1724).

Part Number Selection

Use EPG Model 512/1712 for operation in 12-volt systems. Use Model 524/1724 for operation in 24-volt systems.

Additionally, speed controls are available for four ranges of magnetic pickup frequencies, for diesel engines and gas turbines, or for gasoline and gas engines. Actuators have a double-ended output shaft for either clockwise or counterclockwise rotation to increase fuel.

Speed controls and actuators must be compatible. Use the Part Number Selection Table below (Table 1-1) to choose compatible EPG speed controls and actuators.

The optional Start Fuel Limit feature allows setting a maximum actuator position during start-up. The maximum position remains in effect until the engine reaches the selected idle or rated speed. The limit may be adjusted out of the way by turning the adjustment potentiometer fully clockwise.

The Dual Dynamics feature allows tailoring a special set of responses for unloaded and loaded operating conditions. This type of control is often needed for gas engines and other systems with non-linear fuel systems. A switch is used to change between slow and fast dynamics.

Isochronous Speed Control—					
For use with engine type (system battery voltage)	Speed Range (Hz) Required				Actuator Part Number
	750 to 1500	1500 to 3000	3000 to 6000	6000 to 12 000	
Diesel or Gas Turbine (12 V)	8290-062	8290-050	8290-040	8290-063	8256-022 (512) **
Gasoline or Gas Engine (12 V)	8290-064	8290-059	8290-041	8290-051	
Diesel w/ Start Fuel Limit (12 V)			8290-140 8290-186* **		
Gas w/ Start Fuel Limit (12 V)			8290-141 8290-187* **		8256-017 (1712) **
Gasoline or Gas w/ Dual Dynamics (12 V)			8290-158		
Diesel or Gas Turbine (24 V)	8290-061	8290-054	8290-038	8290-060	8256-021 (524) **
Gasoline or Gas Engine (24 V)	8290-057	8290-058	8290-039	8290-052	
Diesel w/ Start Fuel Limit (24 V)		8290-175	8290-138 8290-184* **	8290-172	
Gasoline or Gas w/ Start Fuel Limit (24 V)		8290-174	8290-139 8290-185* **		8256-016 (1724) **
Gasoline or Gas w/ Dual Dynamics (24 V)			8290-118		
Droop Speed Control—					
Diesel or Gas Turbine (12 V)	8290-067	8290-071	8290-046	8290-075	8256-022 (512) **
Gasoline or Gas Engine (12 V)	8290-068	8290-072	8290-047	8290-076	8256-017 (1712) **
Diesel or Gas Turbine (24 V)	8290-069	8290-073	8290-044	8290-077	8256-021 (524) **
Gasoline or Gas Engine (24 V)	8290-070	8290-074	8290-045	8290-078	
Diesel or Gas Turbines w/ Dual Dynamics (24 V)			8290-142		8256-016 (1724) **

*—These part numbers are EU Directive compliant.

**—These part numbers are UL/cUL Listed.

Table 1-1. Part Number Selection Table

Accessories

This manual includes some information about accessories frequently used with EPGs.

To Parallel Generators

Add the Generator Load Sensor to the EPG in paralleled generator applications. Woodward makes many accessories for paralleled generator applications.

To Decrease Acceleration and Deceleration

The Ramp Generator or an optional, external capacitor can be used to increase the time to go from idle to rated speeds and vice versa. The Ramp Generator provides a linear ramp with times adjustable to 25 seconds in a typical case. It is useful in smoke-limiting applications. Use the 8271-909 with 24 V batteries and the 8271-910 for 12 V batteries. The capacitor provides an exponential ramp with times up to four seconds. Exponential means it changes (speed in this case) rapidly at first but slows as it approaches its final value. See the typical wiring diagram for capacitor requirements.

References

These publications can be obtained from your Woodward authorized Distributor or AISF (Authorized Independent Service Facility). All are also available on the Woodward website (www.woodward.com).

Catalog	Title
52122	Woodward Industrial Control Product Line Catalog
Product	
Specification	Title
04106	Model 512/1712 & 524/1724 Electrically Powered Governors
Manual	Title
25070	Electric Governor Installation Guide
82510	Magnetic Pickups for Electric Governors

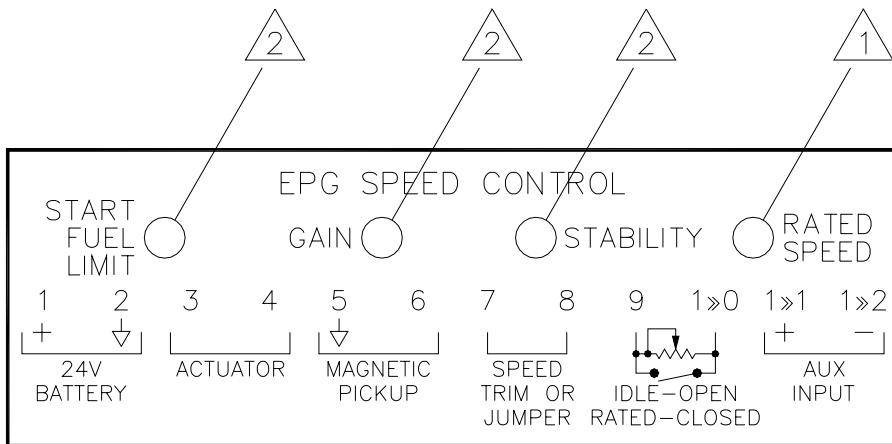
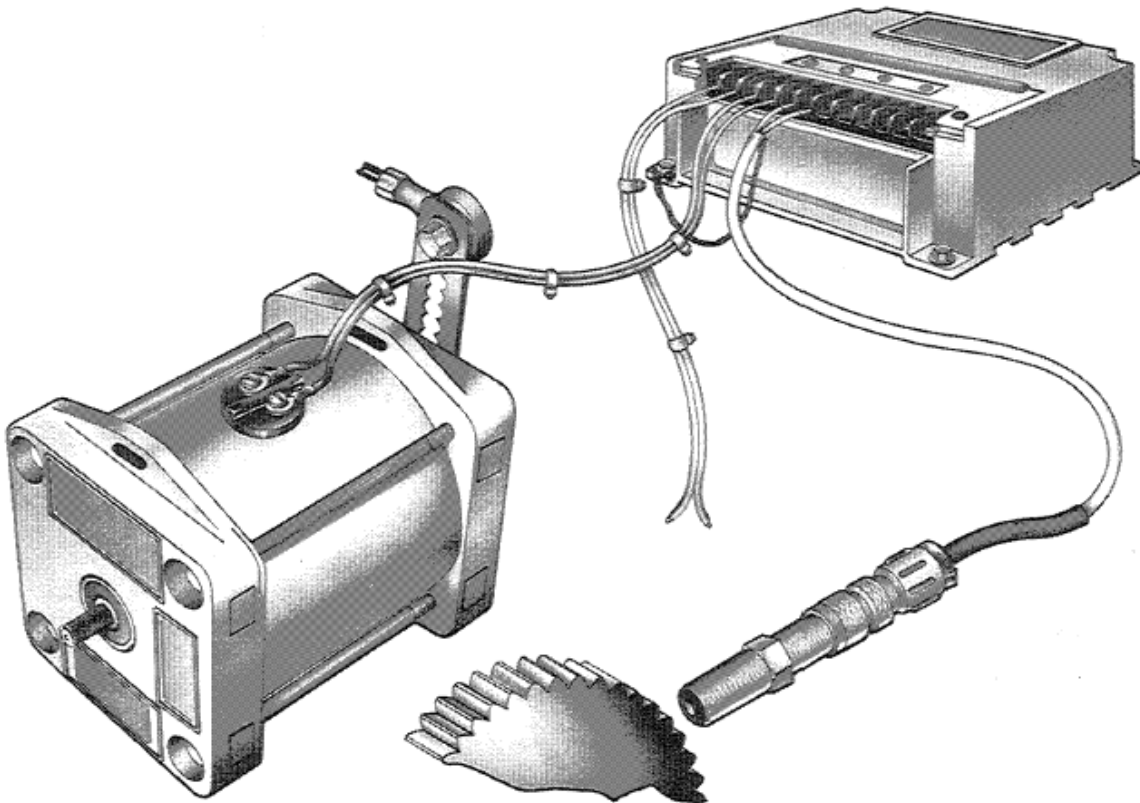

824-306
91-02-20 GA

- ① 25-TURN POTENTIOMETER. RATCHET-TYPE CLUTCHES AT BOTH ENDS OF TRAVEL.
- ② ONE-TURN POTENTIOMETER. SOLID STOPS AT BOTH ENDS OF TRAVEL.

MOST MODELS DO NOT HAVE THE START FUEL LIMIT OR DUAL DYNAMICS.

Figure 1-1. Basic Electrically Powered Governor System

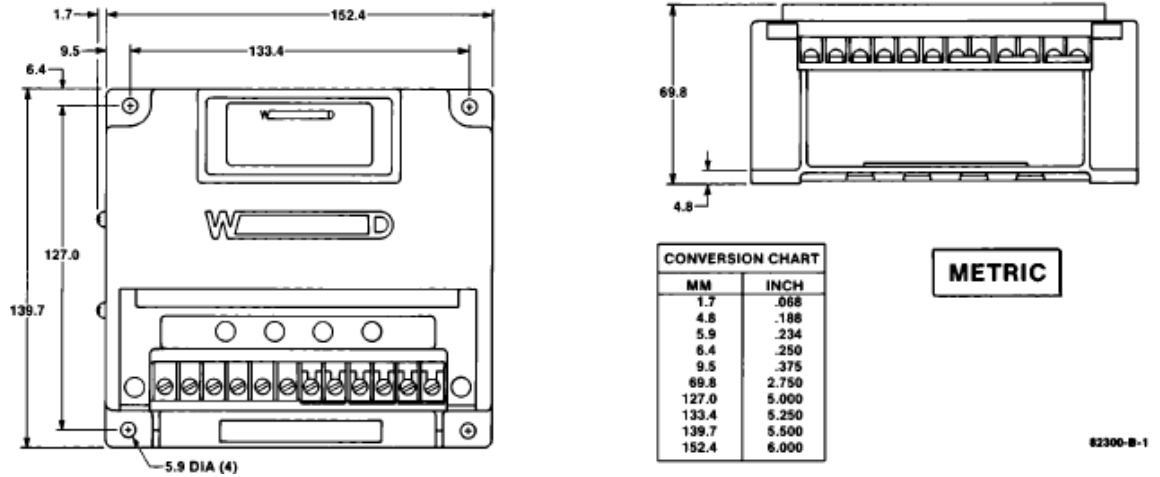

Figure 1-2. Outline Drawing for EPG 512/1712 and 524/1724 Speed Controls
(Do not use for construction.)

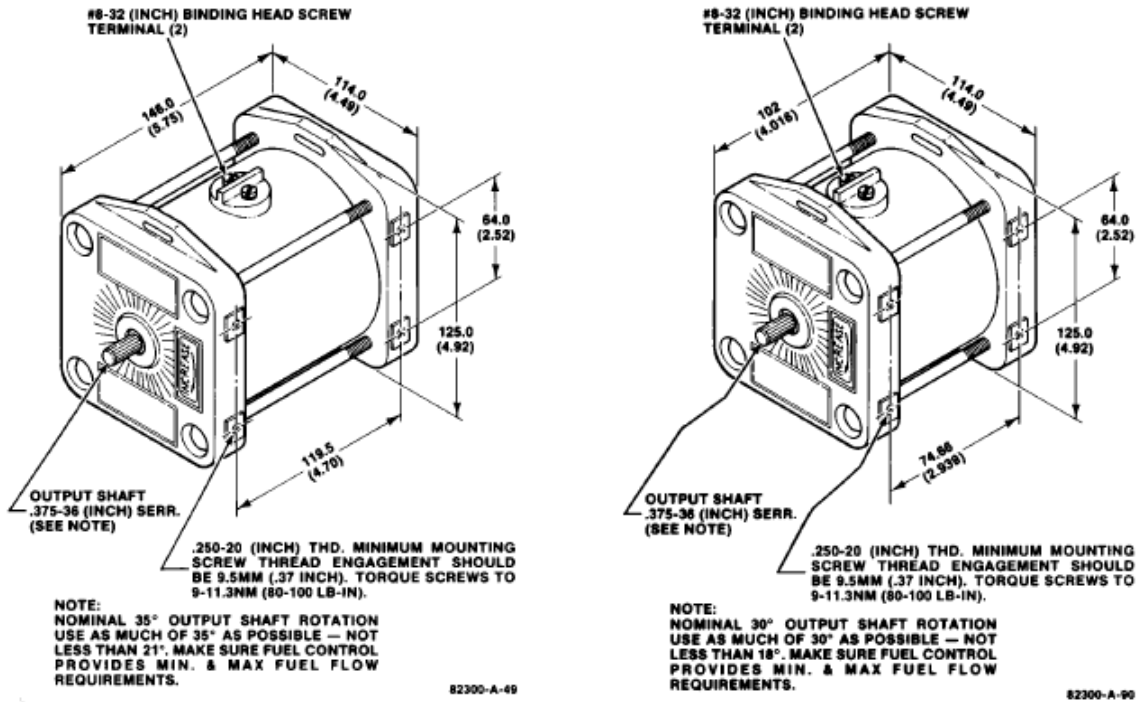

Figure 1-3. Outline Drawing for EPG 1712/1724 and 512/524 Actuators
(Do not use for construction.)

Chapter 2. Installation, Checkout, and Calibration

General

Custom installation kits, including actuator mounting hardware, linkage, and actuator wiring harness, are available for some specific engines. Contact Woodward for more information.



WARNING—OVERSPEED PROTECTION

The engine, turbine, or other type of prime mover should be equipped with an overspeed shutdown device to protect against runaway or damage to the prime mover with possible personal injury, loss of life, or property damage.

The overspeed shutdown device must be totally independent of the prime mover control system. An overtemperature or overpressure shutdown device may also be needed for safety, as appropriate.

Speed Control Mounting

The speed control is designed to operate within a temperature range of -40 to $+75$ °C (-40 to $+167$ °F). Mount the control in a location with space for adjustment and wiring access. If mounted on the prime mover, do not expose the speed control to sources of radiant heat such as exhaust manifolds or turbochargers. Also choose a protected location so that the control won't be damaged when moving the prime mover or when equipment is moving near by. Mount the control close to the actuator and battery to meet the wire length requirements. Allow for adequate ventilation.

Actuator Mounting and Linkage

Actuator location must allow installation of a suitable linkage. The actuators are designed to operate within a temperature range of -40 to $+93$ °C (-40 to $+200$ °F). Do not expose the actuator to sources of excessive heat.

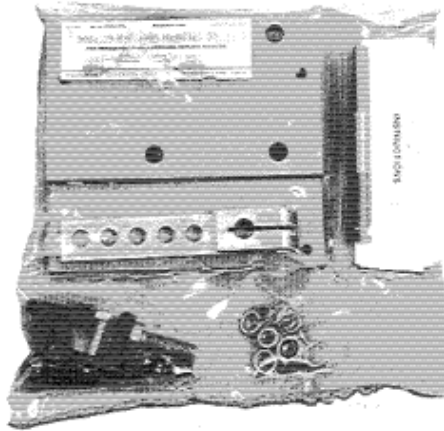

Figure 2-1. Typical Installation Kit

Match the actuator's direction of rotation for increased fuel with the fuel control's direction of rotation for increased fuel by choosing a suitable linkage.

If you are using a Woodward supplied installation kit, follow its instructions and skip over Linkage Compatibility. Begin again with Installing the Magnetic Pickup.

Linkage Compatibility

Also match linkage linearity to the fuel control. Use a linear linkage as shown in Figure 2-2 unless the prime mover has a carburetor or other non-linear fuel control. See Figures 2-3 and 2-4 for a carburetor compensating linkage. Contact Woodward if a linkage different from those shown is required. Incorrect linearity matching can cause stable operation at some fuel settings but oscillation at other fuel settings.

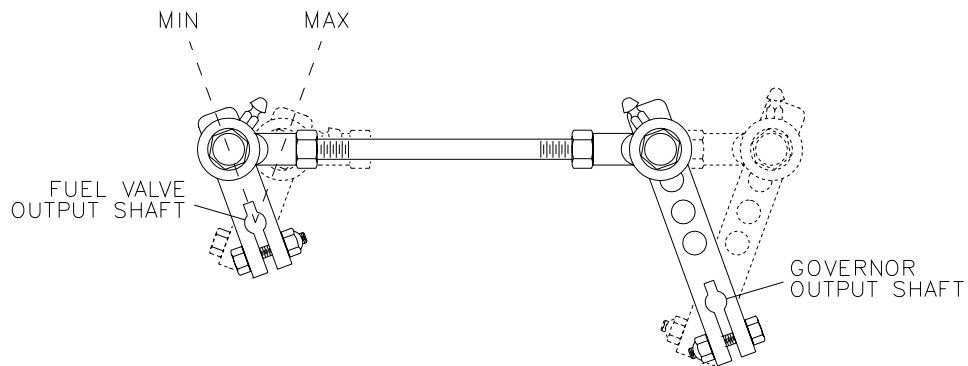

USED ON:

- DIESELS, GAS TURBINES AND FUEL INJECTED ENGINES

250-073
62-7-31

Figure 2-2. Linear Linkage

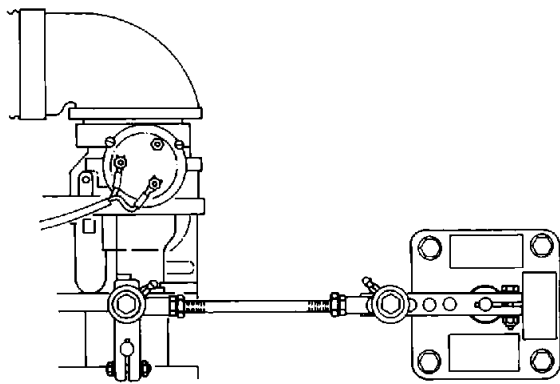

25000-A-74

Figure 2-3. Carburetor Compensating Linkage at Minimum Fuel

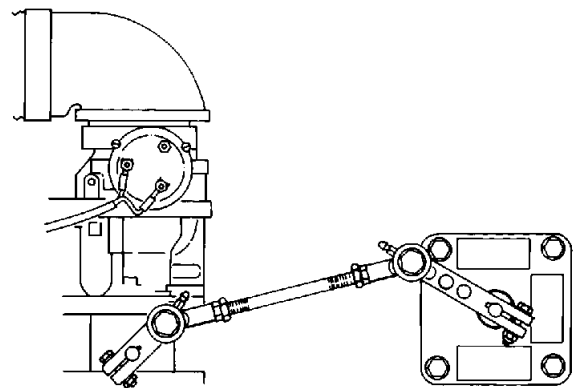

25000-A-75

Figure 2-4. Carburetor Compensating Linkage at Maximum Fuel

Manually stroke the fuel control linkage from stop to stop as if the actuator were moving it. The linkage must move freely without friction and without backlash. Lubricate or replace linkage or fuel control parts as required.

Mount the actuator and install a suitable linkage.

A return spring is included in the actuator. Do not use an additional return spring. (Low force return springs that may be located in an engine's valve cover usually don't affect EPG performance.)

Make sure that the actuator is capable of moving the fuel control to the maximum and minimum limits. Let the fuel control limit actuator travel. Set the linkage so that the actuator is just above minimum when the fuel control is at its minimum stop and (except for Detroit Diesel engines) so that the actuator is just below maximum when the fuel control is at its maximum stop. We recommend that Woodward installation kits be used for Detroit Diesel engines.

Use good rod end connectors. The link connecting the actuator lever to the fuel control lever must not be so long that it flexes when the prime mover is running.

Installing the Magnetic Pickup

Mount the magnetic pickup through a housing or rigid bracket. Make sure that the sensed gear is of magnetic material. The gap between the pickup and the outside diameter of the gear should be set to approximately 1.0 mm (0.04") at the closest point (radial runout). Using the pickup with small gears may require spacing as close as 0.25 mm (0.010").

If you cannot measure the gap directly, it can be set in this manner: with the prime mover shut down, turn the pickup in (clockwise) until it touches the outside diameter of a tooth. Then back out the pickup (counterclockwise) approximately three-quarters of a turn. Run the gear slowly through 360 degree rotation to check the clearance of the pickup. When the gap is set, tighten the jam nut securely against the housing or bracket.

The standard pickup models require mating connectors, MS 3102R-18-3P. The connectors are not furnished with the pickup, but may be ordered from Woodward if desired. See manual 82510, *Magnetic Pickups and Proximity Switches for Electronic Controls*, for more information

Wiring Instructions

Use a wiring diagram for the specific part number of your EPG system to make all wiring connections. The wiring diagram is available from Woodward. Typical wiring is shown in Figure 2-5.

Make all connections using insulated terminals. The wiring from actuator to speed control and from the battery to the speed control must be as short as possible. Maximum wiring lengths are:

Maximum Wiring Length Chart

EPG Model	Maximum Wire Length	
	14 AWG (2 mm ²)	12 AWG (3 mm ²)
512/1712	10 ft (3 m)	20 ft (6 m)
524/1724	35 ft (11 m)	75 ft (23 m)

The fuse and switch or circuit breaker must be in the non-grounded battery lead. Use a fuse or circuit breaker as specified in the Switch and Fuse Requirements Chart. Do not use a fuse of higher current rating. Starter relays make good EPG power switches.

Switch and Fuse Requirements Chart

EPG Model	Voltage	Switch Rating	Fuse
512/1712	12	10 A	10 A
524/1724	24	10 A	10 A

Wire Harness Part Numbers Chart

Harness Part Number	Harness Lengths		
	MPU	Actuator	Battery
8924-621	10 ft (3 m)	15 ft (5 m)	15 ft (5 m)
8924-620	10 ft (3 m)	25 ft (8 m)	25 ft (8 m)

The battery connection to speed control terminals 1 and 2 must be directly from the terminals, not through distribution points (see Figure 2-6).

Do not connect any other wires to terminals 1 and 2 except the power for the 2500 Ramp Generator, if used.



CAUTION—SHUT ENGINE DOWN

To prevent damage to the control, never disconnect the battery while the engine is running.



CAUTION—POWER WIRES

Connect power wires directly to the battery terminals. The speed control can be damaged if these wires are connected to distribution points. See Figure 2-6.

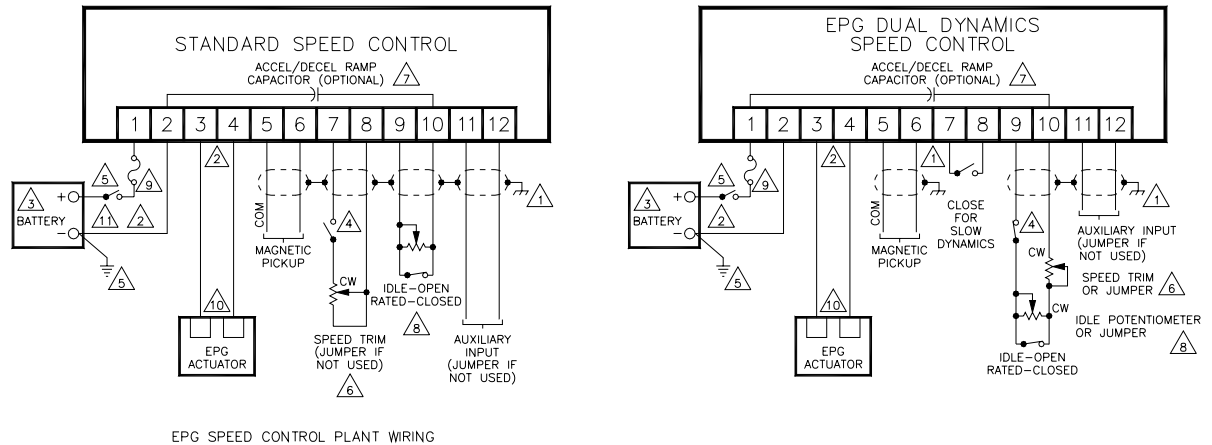

- NOTE:
- 1 SHIELDED WIRES TO BE TWISTED PAIRS OR TWISTED 3 CONDUCTOR, GROUNDED AT ONE END ONLY.
 - 2 NO. 12 AWG OR 14 AWG STRANDED WIRE, MUST BE AS SHORT AS POSSIBLE (SEE MAX LENGTH IN CHART).
 - 3 SEE TEXT FOR VOLTAGE.
 - 4 OPEN FOR MINIMUM FUEL. DO NOT USE EITHER THE MINIMUM FUEL OPTION, OR DISCONNECT THE ACTUATOR LEADS, OR DISCONNECT THE POWER TO THE CONTROL AS PART OF ANY EMERGENCY STOP SEQUENCE.
 - 5 FOR POSITIVE GROUND SYSTEMS, SWITCH AND FUSE TO BE LOCATED IN SERIES WITH BATTERY (-) AND TERMINAL 2. POS TERMINAL BECOMES CHASSIS GROUND. LEADS FROM BATTERY TO TERMINALS 1 & 2 MUST BE DIRECT AND NOT PASS THROUGH DISTRIBUTION POINTS. USE 10 A FUSE AND SWITCH.

- 6 APPROXIMATE SPEED CHANGE WITH TRIM POTENTIOMETER:
±2.5% USING A 1K OHM POTENTIOMETER
±5% USING A 2K OHM POTENTIOMETER
- 7 APPROXIMATELY ONE SECOND RAMP TIME PER 50 UF. CAPACITOR SPECIFICATION: 200 UF MAXIMUM 15 WVDC MINIMUM, LESS THAN 30 UA DC LEAKAGE CURRENT OVER TEMPERATURE RANGE.
- 8 IDLE RANGE APPROXIMATELY 25% TO 100% OF RATED USING 50K POTENTIOMETER. FOR FIXED IDLE SPEED, CALCULATE THE VALUE OF THE RESISTOR:
$$R = 17 \text{ K OHM } \left(\frac{\text{RATED SPEED}}{\text{IDLE SPEED}} - 1 \right)$$

JUMPER IF IDLE SPEED IS NOT USED.
- 9 USE A 10 AMP FUSE (3 AG OR GBB TYPE).
- 10 POLARITY NOT IMPORTANT.
- 11 CONNECT CONTROL WIRES ONLY AT BATTERY POSTS, NOT AT OTHER CONNECTION POINTS.

Figure 2-5. Typical EPG (Isochronous) Wiring Diagram
(Do not use for construction.)

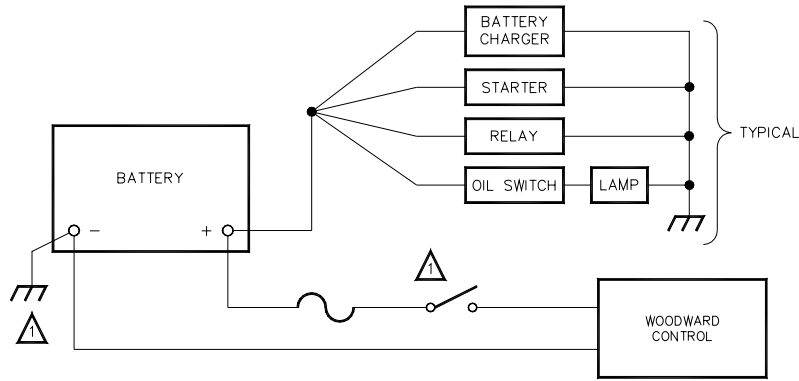

NOTE:

⚠ A NEGATIVE GROUND SYSTEM IS SHOWN. IF A POSITIVE GROUND SYSTEM IS USED, THE SWITCH AND FUSE MUST BE LOCATED IN SERIES WITH BATTERY (-) AND TERMINAL (TB1-2) ON THE WOODWARD CONTROL. THE POSITIVE TERMINAL BECOMES CHASSIS GROUND.

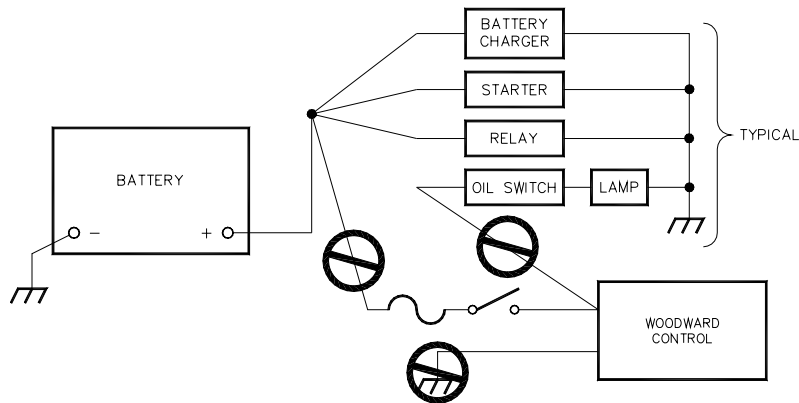

824-143
97-08-22 skw

Figure 2-6. Correct and Incorrect Wiring to Battery

To satisfy EMC requirements, a varistor must be attached to the input power connection pins (1 & 2). The varistor should be equivalent to a V47ZA7.

Shields

Connect shields as shown in your wiring diagram. Terminate shields at a chassis mounting screw. Only one end of each shield (the end nearest the speed control) should be tied to ground. All shields must be tied to the same point.

When passing shields through connectors and terminal block, treat each shield as if it were a signal wire. Each shield must be given its own pin or terminal and be kept insulated from nearby wires and metal conductors. Do not tin (solder) braided shields.

Connect the speed control chassis to system ground ().

Additional Wiring for 2500 Ramp Generators (optional)

Connect the 2500 Ramp Generator terminals 1 and 2 to speed control terminals 1 and 2, respectively. Connect 2500 Ramp Generator terminal 4 to speed control terminal 10 with a shielded wire. Connect the shield, at the speed control, to a chassis mounting screw for grounding. Do not connect the shield at the ramp generator end.

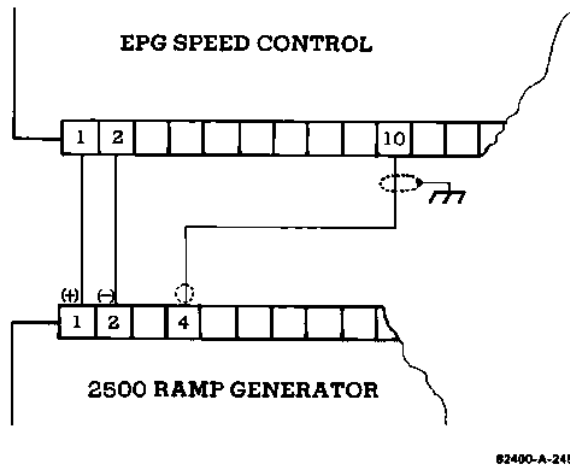

Figure 2-7. Typical Wiring to 2500 Ramp Generator

Additional Wiring for EPG Load Sensor (optional)

Mount the Load Sensor where it will be between -40 and $+71$ °C (-40 and $+160$ °F). Do not mount it on the prime mover. The best location is usually the switchgear cabinet which has the CTs and PTs.

Wire the Load Sensor as shown in the diagram for additional wiring. Careful attention to correct CT and PT wiring can save time during the phasing checks later on. Install appropriate voltage selection jumpers at terminals 17 through 20. Refer to Manual 82313, *Generator Load Sensor 8290-048*, for load sensor information.

Contact Woodward before connecting anything other than the 8290-048 Load Sensor to terminals 11 and 12 of the EPG Speed Control.

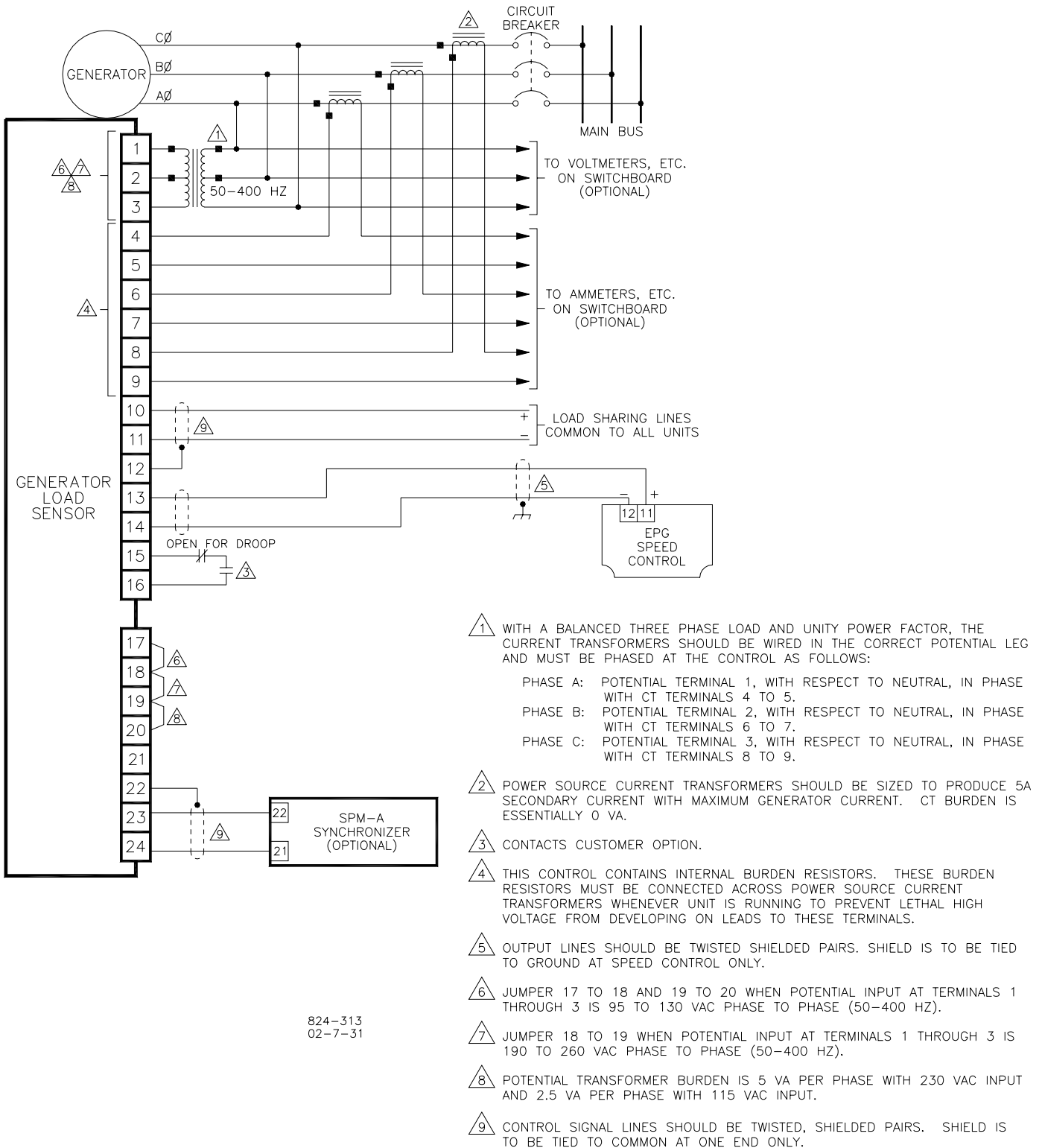

824-313
02-7-31

Figure 2-8. Additional Wiring to Install the EPG Load Sensor (for paralleled generator applications)

Installation Checks

Checks for all Applications

The following steps check only the speed control and actuator, which must work correctly before paralleling the generator. Since most faults appear when the prime mover is first run, this step-by-step approach eliminates most problems before they occur. The main part of Chapter 5 (Troubleshooting) is doing these checks.

If a Load Sensor is used, temporarily remove the wires at speed control terminals 11 and 12 and temporarily jumper terminals 11 to 12. The generator must not be paralleled during these tests. If a Ramp Generator is used, temporarily remove the wire at speed control terminal 10. If a capacitor is connected to terminal 10 to provide a ramp between unloaded and loaded, it must be removed during this test or calibration. Leave the idle-rated switch wiring connected. Do the checks in the order indicated. Terminal numbers in this section refer to the speed control.

1. Check that all electrical connections are correctly made and terminal screws are tight; the magnetic pickup is properly installed and the jam nut is tight; the actuator and linkage are securely fastened. If start-fuel limit is present, turn the adjustment fully clockwise during these tests. If dual dynamics are present, set the switch closed for slow dynamics.
2. Do **not** start the prime mover now. Turn on governor power. If the fuse or breaker opens as soon as power is applied, the battery polarity (terminals 14 and 15) is probably reversed. The actuator shaft can jump when power is turned on, but must quickly come back to the minimum fuel position. Check the battery voltage at terminal 1 (+) and 2 (-). It must be from 10 to 16 Vdc for 512/1712 controls, and from 20 to 32 Vdc for 524/1724 controls.
3. Disconnect any wiring or jumper on terminal 7. Measure 7.2 ± 1.0 V from terminal 2 (-) to 7 (+) [terminals 2 (-) to 9 (+) for dual-dynamics control]. Reinstall the wiring to terminal 7 if voltage is correct. Do not use the control if voltage is incorrect.
4. If idle speed is desired, connect a 50 k Ω potentiometer or fixed resistor to terminals 9 and 10 as shown in the typical wiring diagram. To calculate the value of a fixed resistor:

$$R = 17 \text{ k}\Omega \left(\frac{\text{Rated Speed}}{\text{Idle Speed}} - 1 \right)$$

5. Put the idle-rated switch in the rated position or jumper terminals 9 and 10. Measure the voltage from terminal 7 (+) to 2 (-). Put the idle-rated switch in the idle position or remove the jumper. The voltage must increase. If it does not increase, check the speed trim pot, if used, and the idle-rated switch wiring.
6. If a signal generator with an isolated output is available, the failsafe and actuator travel can be checked, Rated and idle speed can be preset. If a signal generator is not available, skip to step 7.

Turn off governor power. Remove the magnetic pickup wires from terminals 5 and 6. Connect the signal generator to terminals 5 and 6. Set the output between 2 and 10 Vrms. The wave form can be sine, square, or triangular. Calculate the MPU frequency for idle and rated speeds (see part number selection in Chapter 1).

Check Failsafe and Actuator Travel:

Set the signal-generator frequency to about half of idle speed. Set the idle-rated switch to rated. Turn the signal generator and governor power on. The linkage must be at the maximum-fuel position. Except for Detroit Diesel engines, verify that linkage travel is limited by the prime-mover fuel control, not by the actuator stop. Turn the signal generator off and remove the connections at terminals 5 and 6. The linkage should move to the minimum fuel position. Verify that linkage travel is limited by the prime mover's fuel control, not by the actuator stop.

Preset Rated Speed:

Set the signal generator for MPU frequency at rated speed and connect it to terminals 5 and 6. Put the idle-rated switch in the rated position. Set the speed trim pot, if connected, to mid-position. Observe the linkage position.

If the linkage is at the maximum fuel position:

Slowly turn the rated speed pot counterclockwise until the linkage just begins to move to the minimum fuel position. Start Fuel (if present) must be adjusted to the maximum clockwise position or the actuator will not move to maximum.

If the linkage is at the minimum fuel position:

Slowly turn the rated speed pot clockwise until the linkage just begins to move to the maximum fuel position.

Continue to adjust the rated speed pot very slowly in the appropriate direction, trying to stop the linkage between the minimum and maximum fuel stops. Because it is not possible to stop the motion, cease adjusting when the linkage moves slowly. The rated speed reference is now set very close to desired speed. A slight adjustment when the engine is running will achieve the exact speed.

Preset Idle Speed:

Preset idle speed only after presetting rated speed. Set the signal generator for the MPU frequency at idle speed. Put the idle-rated switch in the idle position. Observe the linkage position.

If the linkage is at the maximum fuel position:

Slowly turn the idle speed pot counterclockwise until the linkage just begins to move to the minimum fuel position. Start Fuel (if present) must be adjusted to the maximum clockwise position or the actuator will not move to maximum.

If the linkage is at the minimum fuel position:

Slowly turn the idle speed pot clockwise until the linkage just begins to move to the maximum fuel position.

Continue to adjust the idle speed pot very slowly in the appropriate direction, trying to stop the linkage between the minimum and maximum fuel stops. Because it is not possible to stop the motion, cease adjusting when the linkage moves slowly. The idle speed reference is now set very close to desired speed. A slight adjustment when the engine is running will achieve the exact speed.

7. If the idle and rated speed pots were not preset with a signal generator, set the rated speed pot fully counterclockwise.

8. Remove the MPU wires from speed control terminals 5 and 6. Measure the resistance of the MPU at the wire ends. It should be between 100 and 300 Ω . Reconnect the MPU wires.
9. Set the idle-rated switch for rated speed. Turn governor power on.

**WARNING—START-UP**

Be prepared to make an emergency shutdown when starting the engine, turbine, or other type of prime mover, to protect against runaway or overspeed with possible personal injury, loss of life, or property damage.

10. Gain and Stability
Set the gain and stability pots to mid-position. (Units with dual dynamics should select Slow Dynamics if the goal is to have separate dynamics for loaded and unloaded conditions. If the dual dynamics are being used for dual-fuel engines, select and set the dynamics that fit the starting fuel.)

Connect an ac voltmeter to speed control terminals 5 and 6 to measure the MPU voltage. Start the prime mover and check the MPU voltage. It must be at least 1.5 Vrms while cranking.

If the prime mover does not start, check the linkage while cranking. If it is at the maximum fuel position, the EPG is operating correctly. Check the fuel supply, ignition, etc.

If the linkage is not at the maximum fuel position, cranking speed can be greater than the speed reference. (The Start Fuel Limit must be fully clockwise on controls with Start Fuel Limit.) Measure the resistance from speed control terminal 9 to 10. It must be a short circuit (0 Ω). If not, the idle-rated switch is in the idle position, or the switch or wiring is defective. Place in rated position or repair. If the resistance is 0 Ω , the rated speed reference can be lower than cranking speed. Turn the rated-speed pot clockwise four turns and try to restart. Be prepared to quickly adjust rated speed counterclockwise to minimize overspeed if the prime mover starts. If it still doesn't start, turn the rated-speed pot fully counterclockwise to minimize overspeed when it does start. Refer to Chapter 5 (Troubleshooting).

When the prime mover starts, slowly turn the gain pot back and forth to observe high and low frequency oscillation. (Be sure to select the correct low-speed or high-speed dynamics pot on units with dual dynamics.) Eliminate oscillation by slowly turning the gain pot for the stable region between high and low frequency oscillation. If oscillation does not stop at the high-low crossover, turn the stability pot slightly counterclockwise and slowly readjust the gain pot. Continue adjusting the stability pot slightly counterclockwise followed by readjusting gain until the prime mover runs at a steady speed. (The stability pot adjusted must be for the same dynamics as the gain pot on dual dynamics units.)

By turning gain slightly clockwise and stability slightly counterclockwise, or vice-versa, it is possible to maintain stable speed and vary transient response. The four curves on the response curve diagram are examples of a naturally aspirated (not turbocharged) diesel engine. Note that increasing gain and decreasing stability causes shorter settling times at the expense of ringing. A chart recorder makes it easier to observe transient response.

Check response after each adjustment by momentarily changing speed. Repeat the following tuning procedure until the prime mover responds as desired. Note that settings with high gain and low stability can result in stable operation at normal temperatures and oscillation when the prime mover is cold.

To decrease settling time, turn the gain pot clockwise. Turn the stability pot counterclockwise as required to eliminate oscillation and obtain the desired response.

To decrease ringing, turn the stability pot clockwise. Turn the gain pot counterclockwise as required to eliminate oscillation and obtain the desired response.

Check response by applying and removing load, manually hitting the linkage, or quickly switching to idle and back to rated speed.

(Units with Dual Dynamics will require setting of the second dynamics under the operating conditions where they will be used—such as engine loaded or a different fuel being used. Repeat step 10 in its entirety to set the second set of dynamics.)

11. Setting Speed References

The prime mover should not be oscillating. Make sure the idle-rated switch is in the rated speed position. Adjust the rated speed pot for exactly rated speed. Set the idle-rated switch for idle speed. Adjust the idle speed pot for the desired idle speed. Set the idle-rated switch back to rated.

12. Set the Start Fuel Limit on units so equipped at mid-position. Attempt to start the engine. If the actuator moves to a position higher than desired, adjust slightly counterclockwise. To increase the start fuel position, turn the potentiometer clockwise. In most diesel applications the ideal setting will be where the engine starts with a minimum amount of ejected smoke. Start Fuel Limit is adjusted on gas fueled engines to prevent flooding while allowing the engine to start. The Start Fuel Limit will be overridden should the cranking speed of the engine exceed the selected idle or rated speed.

Checks for Applications with the 2500 Ramp Generator

Reconnect the ramp generator output to terminal 10 of the speed control. Turn the accel time and decel time pots counterclockwise four turns. Switch from rated speed to idle and back, noting the time it takes each way. Turn the accel and decel pots two turns clockwise. Check that it now takes longer to go from rated to idle and from idle to rated. Set each pot for the desired time.

Paralleled Generator Applications with the Load Sensor

See Manual 82313, *Generator Load Sensor 8290-048*, for information concerning load sensor.

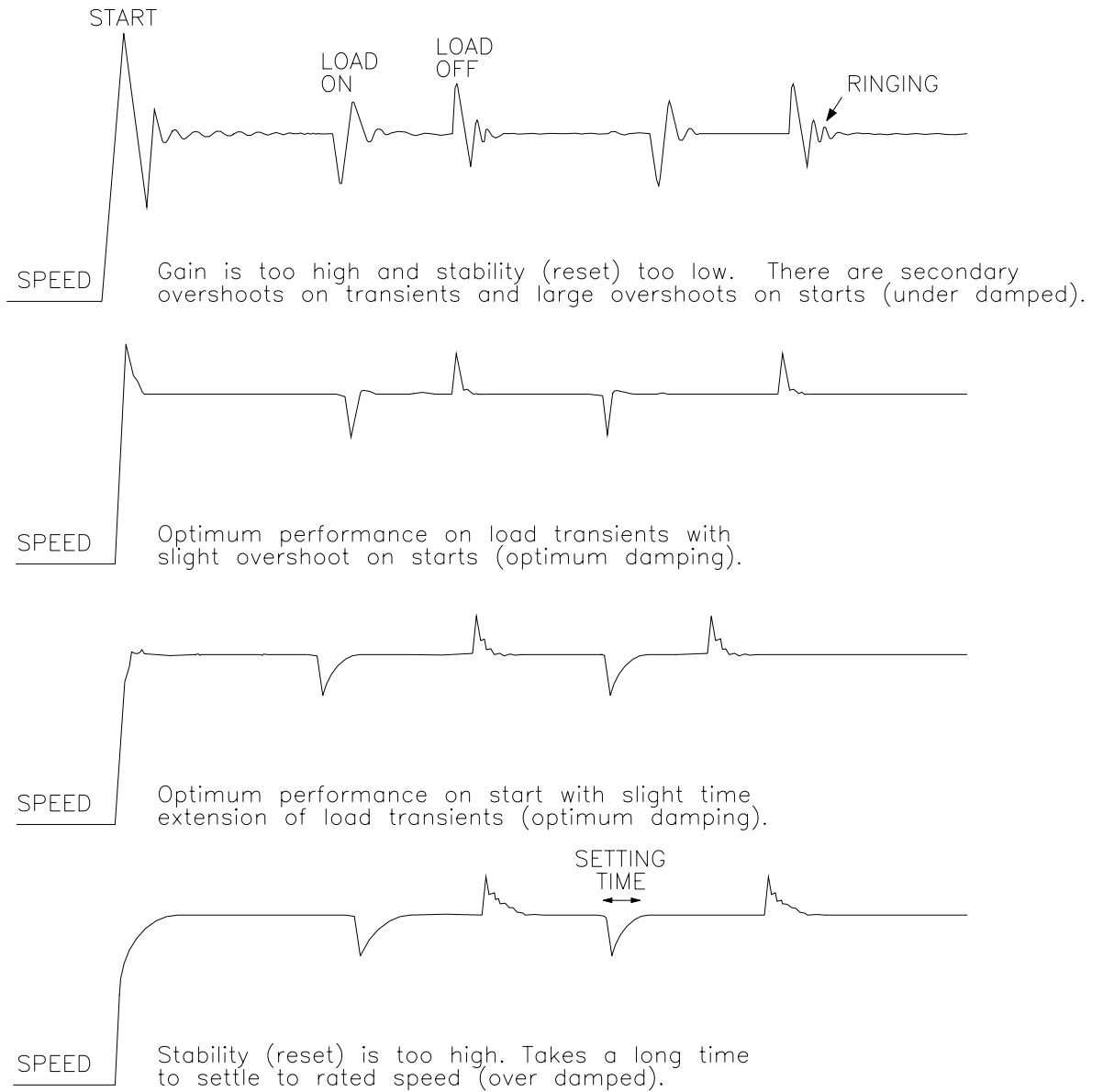

851-004D
02-7-31

Figure 2-9. Starting and Transient Response Curves

Chapter 3. Operation

The speed control requires that power be on when starting, and that power be off when stopping (power off causes shutdown if fuel flow is stopped when the fuel control is at the minimum fuel position). Paralleled generator applications require synchronizing and paralleling. If paralleling in droop mode, a speed trim pot adjustment is required to set the amount of power generated.

The EPG is designed for unattended operation. Governor power can be controlled by the prime mover's start-stop control.

The idle-rated switch can be controlled by devices such as an oil pressure switch or a time switch. Alternatively, the prime mover can run to rated speed on starting (refer to the curves in Figure 2-9). Paralleled generator applications can be equally automatic when a Woodward SPM Synchronizer is used.

In both automatically and manually controlled applications, a Ramp Generator can be used to provide adjustable time to go from rated to idle speeds.

Chapter 4. Description

Speed Control Applications

Speed Control

The basic speed control components and connections are shown in Figure 1-1. There are no mechanical drive or hydraulic connections. All input power comes from the battery. The speed control compares the actual speed with the desired speed. It then calculates an error signal and drives the actuator in the increase or decrease fuel direction to correct prime mover speed.

Figure 4-1 shows the Electrically Powered Governor in more detail. The speed control is housed in a die-cast aluminum enclosure.

The EPG has two control loops. The speed loop ensures prime mover speed remains constant. The current loop ensures proper drive to the actuator.

Speed Loop

The speed loop controller has two inputs: the desired speed (speed reference signal) and the actual speed (the speed sensor signal). It compares the two and calculates an error signal which includes dynamic response considerations. Gain and stability adjustments tailor the governor's response to the requirements of the specific prime mover. Rated speed is set by the rated speed pot and, if attached, a speed trim pot. The idle reference is controlled by an external idle speed pot. Rated speed should be set before idle speed. Speed sensor output is a voltage proportional to magnetic pickup frequency. The frequency range of the magnetic pickup is set by an internal resistor. The specific frequency range of a specific EPG Speed Control is indicated by the part number of the speed control.

Current Loop

The current loop error signal can be considered a command for the correct amount of actuator current.

The actuator's controller circuit compares actual current (from the current sensor circuit) to the desired current level (from the speed loop controller) and generates a current loop error signal. To make the current driver efficient, it is operated as a switch. Actuator current is changed by changing the duty cycle. The pulse width modulator converts the current loop error signal from a dc voltage to a switching signal. For this reason measurements of speed control output [3 (+) and 4 (-)] indicate only general conditions. Excessive currents are prevented from flowing through the actuator coil by the energy limiter. It prevents the actuator from overheating but allows enough current to keep the actuator at the maximum fuel position.

The auxiliary input is jumpered except when a Load Sensor is added for paralleled generator applications. There is a failsafe circuit which senses MPU frequency and forces the pulse width modulator input to zero if the MPU frequency or voltage are below acceptable limits, as they would be if an MPU wire broke.

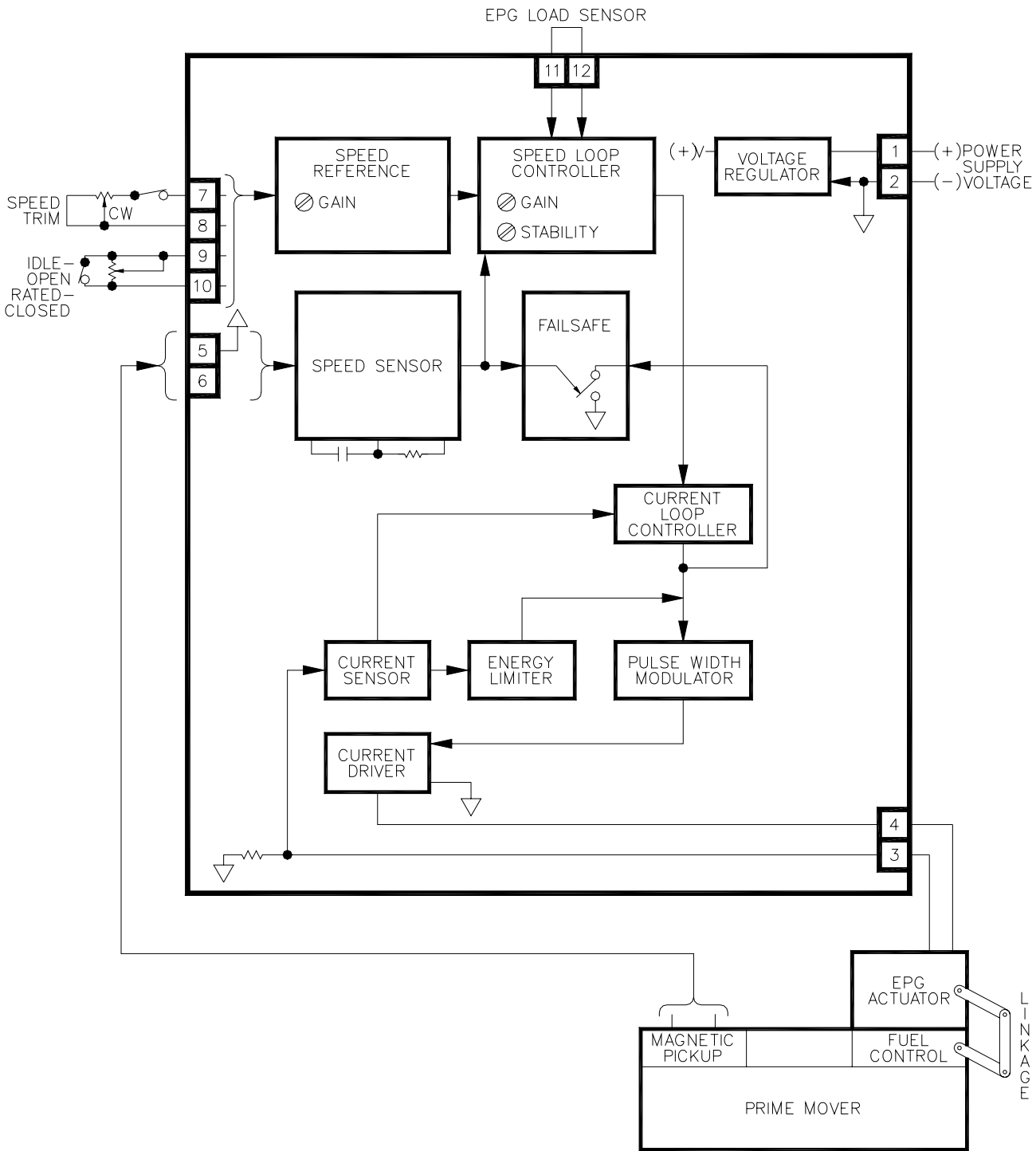

824-098B
90-8-28 GA

Figure 4-1. EPG Block Schematic Diagram

Actuator

As shown in Figure 4-2, the actuator is mechanically simple. It has specially designed rotor and stator which provide reliable, effective performance. The rotary design gives 35° * shaft rotation to low-mass, low-friction fuel controls. The magnetic circuit, when powered by the speed control, applies torque in the increase-fuel direction. Two ** preloaded internal return springs supply shaft torque in the decrease fuel direction. The preload can be factory reduced to compensate for some external linkage forces acting in the decrease fuel direction.

*—For 1712/1724 Actuators, and 30° for 512/524 Actuators.

**—Two springs for 1712/1724 Actuators; one spring for 512/524 Actuators.

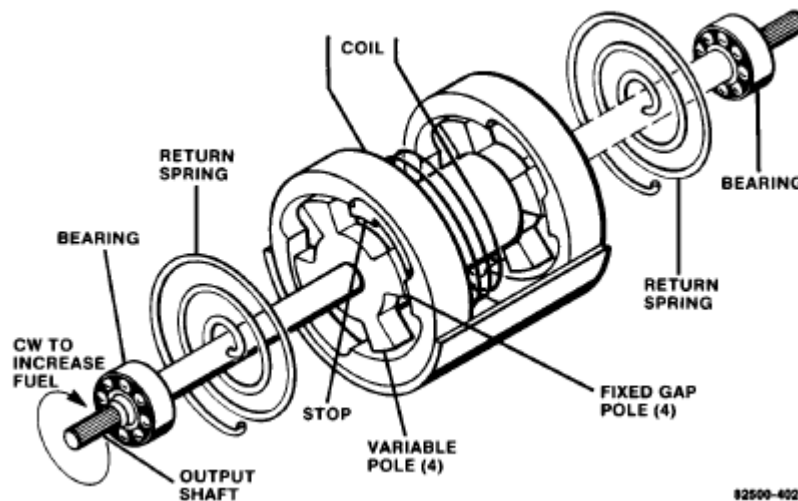

Figure 4-2. Actuator Schematic

Applications Using a Ramp Generator

The Ramp Generator slows the speed change between idle and rated speeds. It has no effect on steady-state speeds. Once set it provides a constant speed change per second by biasing the speed reference when changing from idle to rated and vice versa. The accel and decel pots control the rate of change. Acceleration and deceleration times depend on accel and decel pot settings and the difference between idle and rated speeds.

Paralleled Generator Applications

A Load Sensor is used with the EPG for isochronous or droop paralleling.

With an isolated bus, isochronous load sharing is usually chosen. In an isochronous load sharing system, the load gain signal voltage is shared with all other controls through paralleling lines, and provides an average load gain signal used by the controller circuits.

By comparing the paralleling line voltage to its own load gain voltage, the controller calculates an output to raise or lower, as necessary, the generator output to make the load gain voltage of its unit equal to the paralleling line. Load Sensor output directly biases the speed loop controller circuit of the speed control to affect the actuator fuel level setting and precisely maintain its proportional share of system load while maintaining a fixed frequency. See Figure 2-8, Additional Wiring to Install the EPG Load Sensor.

Droop operation is required when paralleling with an infinite bus or units not having compatible electric governors. The Load Sensor and Speed Control can be in isochronous when used against an infinite bus with a Generator Loading Control or Import/Export Control. The Droop signal then comes from either the Generator Loading Control or the Import/Export Control.

Chapter 5.

Troubleshooting

Troubleshooting Procedure

Even though governor faults cause improper prime mover operation, improper prime mover operation can be also caused by other items such as low fuel pressure. When the prime mover stops working properly, find out which part is defective. Do this by:

1. Substituting, if available, a part that works for the one suspected of causing the problem.
2. Simplifying the system. Remove options and observe performance after each removal.
3. Testing the parts suspected of causing the problem. Follow the manufacturer's instructions or set up input and operating conditions which produce known outputs.

To test the EPG, use Chapter 2 to verify that the installation is correct and perform the installation check. Those checks are the best way to test the EPG. The Preset Rated Speed section (under Step 6 of the Installation Checks in Chapter 2) is the best test of the EPG's ability to control speed. It requires the use of a signal generator with an isolated output. If appropriate, do the checks for Paralleled Generator Applications with the Load Sensor (referenced in Chapter 2, from manual 82313).

Other Checks

Do the installation checks described in the previous paragraph first. Then check the following:

1. If the prime mover is stable at some speeds or power outputs but oscillates at others, the linkage may not be compatible with the fuel control. Refer to Linkage Compatibility under Actuator Mounting and Linkage in Chapter 2.
2. If the prime mover oscillates at low frequency (about 1 Hz) and the Gain and Stability adjustments (in Chapter 2) are correct, then friction in the linkage may be the cause.
 - Disconnect the actuator from the fuel control.
 - Manually stroke the fuel control linkage from stop to stop as if the actuator were moving it. The linkage must move freely without friction and without backlash. Lubricate or replace linkage or fuel control parts as required.
3. If the prime mover is unstable only when load sharing, verify that:
 - Load sensor CTs and PTs are wired correctly.
 - Voltage regulator droop or cross current compensation is set correctly.
 - The voltage regulator is not intermittent or otherwise faulty.

If the problem is still there, reduce the load gain a little and set the load gain pot on all other load sensors in the system for the same load signal at full load. It may be necessary to reduce the load signal to 3 volts in extreme cases. Consult with your authorized Distributor or with Woodward in such cases.

4. If the fuse or breaker opens after the prime mover has been running, high voltage spikes from the battery or battery charger may be the problem. Provide separate wires from the speed control to the battery terminals as shown in the top of figure 2-6.
5. If the fuse or breaker opens upon initial start-up, the battery connections may be incorrect. Verify that the battery connections are correct. Remove the wires to terminals 1 through 4. Check for a short to ground on each wire.
6. If the prime mover oscillates when cold and stabilizes when warm, turn the gain pot slightly counterclockwise. Turn the stability pot slightly clockwise if required to maintain stability.

Chapter 6. Service Options

Product Service Options

The following factory options are available for servicing Woodward equipment, based on the standard Woodward Product and Service Warranty (5-01-1205) that is in effect at the time the product is purchased from Woodward or the service is performed:

- Replacement/Exchange (24-hour service)
- Flat Rate Repair
- Flat Rate Remanufacture

If you are experiencing problems with installation or unsatisfactory performance of an installed system, the following options are available:

- Consult the troubleshooting guide in the manual.
- Contact Woodward technical assistance (see “How to Contact Woodward” later in this chapter) and discuss your problem. In most cases, your problem can be resolved over the phone. If not, you can select which course of action you wish to pursue based on the available services listed in this section.

Replacement/Exchange

Replacement/Exchange is a premium program designed for the user who is in need of immediate service. It allows you to request and receive a like-new replacement unit in minimum time (usually within 24 hours of the request), providing a suitable unit is available at the time of the request, thereby minimizing costly downtime. This is also a flat rate structured program and includes the full standard Woodward product warranty (Woodward Product and Service Warranty 5-01-1205).

This option allows you to call in the event of an unexpected outage, or in advance of a scheduled outage, to request a replacement control unit. If the unit is available at the time of the call, it can usually be shipped out within 24 hours. You replace your field control unit with the like-new replacement and return the field unit to the Woodward facility as explained below (see “Returning Equipment for Repair” later in this chapter).

Charges for the Replacement/Exchange service are based on a flat rate plus shipping expenses. You are invoiced the flat rate replacement/exchange charge plus a core charge at the time the replacement unit is shipped. If the core (field unit) is returned to Woodward within 60 days, Woodward will issue a credit for the core charge. [The core charge is the average difference between the flat rate replacement/exchange charge and the current list price of a new unit.]

Return Shipment Authorization Label. To ensure prompt receipt of the core, and avoid additional charges, the package must be properly marked. A return authorization label is included with every Replacement/Exchange unit that leaves Woodward. The core should be repackaged and the return authorization label affixed to the outside of the package. Without the authorization label, receipt of the returned core could be delayed and cause additional charges to be applied.

Flat Rate Repair

Flat Rate Repair is available for the majority of standard products in the field. This program offers you repair service for your products with the advantage of knowing in advance what the cost will be. All repair work carries the standard Woodward service warranty (Woodward Product and Service Warranty 5-01-1205) on replaced parts and labor.

Flat Rate Remanufacture

Flat Rate Remanufacture is very similar to the Flat Rate Repair option with the exception that the unit will be returned to you in “like-new” condition and carry with it the full standard Woodward product warranty (Woodward Product and Service Warranty 5-01-1205). This option is applicable to mechanical products only.

Returning Equipment for Repair

If a control (or any part of an electronic control) is to be returned to Woodward for repair, please contact Woodward in advance to obtain a Return Authorization Number. When shipping the item(s), attach a tag with the following information:

- name and location where the control is installed;
- name and phone number of contact person;
- complete Woodward part number(s) and serial number(s);
- description of the problem;
- instructions describing the desired type of repair.



CAUTION—ELECTROSTATIC DISCHARGE

To prevent damage to electronic components caused by improper handling, read and observe the precautions in Woodward manual 82715, *Guide for Handling and Protection of Electronic Controls, Printed Circuit Boards, and Modules*.

Packing a Control

Use the following materials when returning a complete control:

- protective caps on any connectors;
- antistatic protective bags on all electronic modules;
- packing materials that will not damage the surface of the unit;
- at least 100 mm (4 inches) of tightly packed, industry-approved packing material;
- a packing carton with double walls;
- a strong tape around the outside of the carton for increased strength.

Return Authorization Number

When returning equipment to Woodward, please telephone and ask for the Customer Service Department [1 (800) 523-2831 in North America or +1 (970) 482-5811]. They will help expedite the processing of your order through our distributors or local service facility. To expedite the repair process, contact Woodward in advance to obtain a Return Authorization Number, and arrange for issue of a purchase order for the item(s) to be repaired. No work can be started until a purchase order is received.



NOTE

We highly recommend that you make arrangement in advance for return shipments. Contact a Woodward customer service representative at 1 (800) 523-2831 in North America or +1 (970) 482-5811 for instructions and for a Return Authorization Number.

Replacement Parts

When ordering replacement parts for controls, include the following information:

- the part number(s) (XXXX-XXXX) that is on the enclosure nameplate;
- the unit serial number, which is also on the nameplate.

How to Contact Woodward

In North America use the following address when shipping or corresponding:

Woodward Governor Company
 PO Box 1519
 1000 East Drake Rd
 Fort Collins CO 80522-1519, USA

Telephone—+1 (970) 482-5811 (24 hours a day)
 Toll-free Phone (in North America)—1 (800) 523-2831
 Fax—+1 (970) 498-3058

For assistance outside North America, call one of the following international Woodward facilities to obtain the address and phone number of the facility nearest your location where you will be able to get information and service.

<u>Facility</u>	<u>Phone Number</u>
Brazil	+55 (19) 3708 4800
India	+91 (129) 230 7111
Japan	+81 (476) 93-4661
The Netherlands	+31 (23) 5661111

You can also contact the Woodward Customer Service Department or consult our worldwide directory on Woodward's website (www.woodward.com) for the name of your nearest Woodward distributor or service facility.

Engineering Services

Woodward Industrial Controls Engineering Services offers the following after-sales support for Woodward products. For these services, you can contact us by telephone, by email, or through the Woodward website.

- Technical Support
- Product Training
- Field Service

Contact information:

Telephone—+1 (970) 482-5811

Toll-free Phone (in North America)—1 (800) 523-2831

Email—icinfo@woodward.com

Website—www.woodward.com

Technical Support is available through our many worldwide locations or our authorized distributors, depending upon the product. This service can assist you with technical questions or problem solving during normal business hours. Emergency assistance is also available during non-business hours by phoning our toll-free number and stating the urgency of your problem. For technical support, please contact us via telephone, email us, or use our website and reference **Customer Services** and then **Technical Support**.

Product Training is available at many of our worldwide locations (standard classes). We also offer customized classes, which can be tailored to your needs and can be held at one of our locations or at your site. This training, conducted by experienced personnel, will assure that you will be able to maintain system reliability and availability. For information concerning training, please contact us via telephone, email us, or use our website and reference **Customer Services** and then **Product Training**.

Field Service engineering on-site support is available, depending on the product and location, from one of our many worldwide locations or from one of our authorized distributors. The field engineers are experienced both on Woodward products as well as on much of the non-Woodward equipment with which our products interface. For field service engineering assistance, please contact us via telephone, email us, or use our website and reference **Customer Services** and then **Technical Support**.

Technical Assistance

If you need to telephone for technical assistance, you will need to provide the following information. Please write it down here before phoning:

General

Your Name _____
 Site Location _____
 Phone Number _____
 Fax Number _____

Prime Mover Information

Engine/Turbine Model Number _____
 Manufacturer _____
 Number of Cylinders (if applicable) _____
 Type of Fuel (gas, gaseous, steam, etc) _____
 Rating _____
 Application _____

Control/Governor Information

Please list all Woodward governors, actuators, and electronic controls in your system:

Woodward Part Number and Revision Letter

Control Description or Governor Type

Serial Number

Woodward Part Number and Revision Letter

Control Description or Governor Type

Serial Number

Woodward Part Number and Revision Letter

Control Description or Governor Type

Serial Number

If you have an electronic or programmable control, please have the adjustment setting positions or the menu settings written down and with you at the time of the call.

DECLARATION OF CONFORMITY
According to EN 45014

Manufacturer's Name: WOODWARD GOVERNOR COMPANY (WGC)
Industrial Controls Group

Manufacturer's Address: 1000 E. Drake Rd.
Fort Collins, CO, USA, 80525

Model Name(s)/Number(s): EPG 12V 8290-187 and similiar
EPG 24V 8290-185 and similiar

Conformance to Directive(s): 89/336/EEC COUNCIL DIRECTIVE of 03 May 1989 on
the approximation of the laws of the Member States
relating to electromagnetic compatibility.

Applicable Standards: EN61000-6-2, 2001: EMC Part 6-2: Generic Standards -
Immunity for Industrial Environments
EN61000-6-4, 2001: EMC Part 6-4: Generic Standards -
Emissions for Industrial Environments

We, the undersigned, hereby declare that the equipment specified above conforms to the above Directive(s).

MANUFACTURER

Signature



Full Name

Jennifer R. Williams

Position

Engineering Manager

Place

WIC, Fort Collins, CO, USA

Date

7-25-02.

We appreciate your comments about the content of our publications.

Send comments to: icinfo@woodward.com

Please include the manual number from the front cover of this publication.



WOODWARD

PO Box 1519, Fort Collins CO 80522-1519, USA
1000 East Drake Road, Fort Collins CO 80525, USA
Phone +1 (970) 482-5811 • Fax +1 (970) 498-3058

Email and Website—www.woodward.com

**Woodward has company-owned plants, subsidiaries, and branches,
as well as authorized distributors and other authorized service and sales facilities throughout the world.**

Complete address / phone / fax / email information for all locations is available on our website.