



## Installation and Operation Manual



## ProAct™ III / IV Electric Powered Actuator and Driver

Manual 04127 (Revision B)

## WARNING—DANGER OF DEATH OR PERSONAL INJURY



### WARNING—FOLLOW INSTRUCTIONS

Read this entire manual and all other publications pertaining to the work to be performed before installing, operating, or servicing this equipment. Practice all plant and safety instructions and precautions. Failure to follow instructions can cause personal injury and/or property damage.



### WARNING—OUT-OF-DATE PUBLICATION

This publication may have been revised or updated since this copy was produced. To verify that you have the latest revision, be sure to check the Woodward website:

[www.woodward.com/pubs/current.pdf](http://www.woodward.com/pubs/current.pdf)

The revision level is shown at the bottom of the front cover after the publication number. The latest version of most publications is available at:

[www.woodward.com/publications](http://www.woodward.com/publications)

If your publication is not there, please contact your customer service representative to get the latest copy.



### WARNING—OVERSPEED PROTECTION

The engine, turbine, or other type of prime mover should be equipped with an overspeed shutdown device to protect against runaway or damage to the prime mover with possible personal injury, loss of life, or property damage.

The overspeed shutdown device must be totally independent of the prime mover control system. An overtemperature or overpressure shutdown device may also be needed for safety, as appropriate.



### WARNING—PROPER USE

Any unauthorized modifications to or use of this equipment outside its specified mechanical, electrical, or other operating limits may cause personal injury and/or property damage, including damage to the equipment. Any such unauthorized modifications: (i) constitute "misuse" and/or "negligence" within the meaning of the product warranty thereby excluding warranty coverage for any resulting damage, and (ii) invalidate product certifications or listings.

## CAUTION—POSSIBLE DAMAGE TO EQUIPMENT OR PROPERTY



### CAUTION—BATTERY CHARGING

To prevent damage to a control system that uses an alternator or battery-charging device, make sure the charging device is turned off before disconnecting the battery from the system.



### CAUTION—ELECTROSTATIC DISCHARGE

Electronic controls contain static-sensitive parts. Observe the following precautions to prevent damage to these parts.

- Discharge body static before handling the control (with power to the control turned off, contact a grounded surface and maintain contact while handling the control).
- Avoid all plastic, vinyl, and Styrofoam (except antistatic versions) around printed circuit boards.
- Do not touch the components or conductors on a printed circuit board with your hands or with conductive devices.

## IMPORTANT DEFINITIONS

- A **WARNING** indicates a potentially hazardous situation which, if not avoided, could result in death or serious injury.
- A **CAUTION** indicates a potentially hazardous situation which, if not avoided, could result in damage to equipment or property.
- A **NOTE** provides other helpful information that does not fall under the warning or caution categories.

Woodward Governor Company reserves the right to update any portion of this publication at any time. Information provided by Woodward Governor Company is believed to be correct and reliable. However, no responsibility is assumed by Woodward Governor Company unless otherwise expressly undertaken.

© Woodward 1994  
All Rights Reserved

# Contents

<b>ELECTROSTATIC DISCHARGE AWARENESS .....</b>	<b>III</b>
<b>CHAPTER 1. GENERAL INFORMATION.....</b>	<b>1</b>
<b>CHAPTER 2. DESCRIPTION OF OPERATION .....</b>	<b>7</b>
Introduction.....	7
Electronic Circuits.....	7
4–20 mA Output Models.....	8
Actuator Position Signal .....	8
Actuator .....	8
<b>CHAPTER 3. INSTALLATION.....</b>	<b>11</b>
Driver Installation.....	11
Actuator Installation .....	11
Actuator Bracket.....	12
Linkage .....	13
Electrical Connections.....	14
Shielded Wiring .....	14
Power Supply .....	15
Driver Adjustments .....	16
Actuator Travel .....	17
<b>CHAPTER 4. TROUBLESHOOTING.....</b>	<b>19</b>
Introduction.....	19
Linkage and Actuator Stroke .....	19
<b>CHAPTER 5. SERVICE OPTIONS .....</b>	<b>20</b>
Product Service Options.....	20
Returning Equipment for Repair.....	21
Replacement Parts .....	22
How to Contact Woodward.....	22
Engineering Services .....	23
Technical Assistance.....	24
<b>PROACT III/IV ACTUATOR/DRIVER SPECIFICATIONS.....</b>	<b>25</b>

# Illustrations and Tables

Figure 1-1. ProAct Driver Outline Drawing .....3  
Figure 1-2. ProAct III Actuator Outline Drawing .....4  
Figure 1-3. ProAct IV Actuator Outline Drawing.....5  
Figure 1-4. Plant Wiring Diagram .....6  
Figure 2-1. ProAct III and IV Functional Block Diagram.....7  
Figure 2-2. ProAct III Actuator Cross Section .....9  
Figure 2-3. ProAct IV Actuator Cross Section .....10  
Figure 3-1. Diesel Engine Travel Stops.....12  
Figure 3-2. Use ProAct Travel Stops for Carburetors .....12  
Figure 3-3. Example of Actuator Bracket .....13  
Figure 3-4. Wiring to Power Supply.....16  
Figure 3-5. ProAct Driver Adjustment Locations .....17  
Figure 3-6. Tolerance Limits in Driver Setup.....18

Table 1-1. ProAct Actuator Specifications.....1  
Table 1-2. ProAct Driver Configurations.....1  
Table 1-3. ProAct Accessories .....2

## Electrostatic Discharge Awareness

All electronic equipment is static-sensitive, some components more than others. To protect these components from static damage, you must take special precautions to minimize or eliminate electrostatic discharges.

Follow these precautions when working with or near the control.

1. Before doing maintenance on the electronic control, discharge the static electricity on your body to ground by touching and holding a grounded metal object (pipes, cabinets, equipment, etc.).
2. Avoid the build-up of static electricity on your body by not wearing clothing made of synthetic materials. Wear cotton or cotton-blend materials as much as possible because these do not store static electric charges as much as synthetics.
3. Keep plastic, vinyl, and Styrofoam materials (such as plastic or Styrofoam cups, cup holders, cigarette packages, cellophane wrappers, vinyl books or folders, plastic bottles, and plastic ash trays) away from the control, the modules, and the work area as much as possible.
4. Do not remove the printed circuit board (PCB) from the control cabinet unless absolutely necessary. If you must remove the PCB from the control cabinet, follow these precautions:
  - Do not touch any part of the PCB except the edges.
  - Do not touch the electrical conductors, the connectors, or the components with conductive devices or with your hands.
  - When replacing a PCB, keep the new PCB in the plastic antistatic protective bag it comes in until you are ready to install it. Immediately after removing the old PCB from the control cabinet, place it in the antistatic protective bag.



### **CAUTION—ELECTROSTATIC DISCHARGE**

To prevent damage to electronic components caused by improper handling, read and observe the precautions in Woodward manual 82715, *Guide for Handling and Protection of Electronic Controls, Printed Circuit Boards, and Modules*.



# Chapter 1.

## General Information

The ProAct™ III and ProAct IV drivers convert either a 0–200 mA or 4–20 mA control signal from a Woodward electronic control into a specific actuator position.

The ProAct drivers require a separate electrical supply of 20–32 Vdc. The supply must be capable of supplying a sustained 10 A and a peak 20 A for up to two seconds for both the ProAct III and ProAct IV drivers.

The ProAct III actuator provides up to 14 J (10 ft-lb) of work to move the fuel setting lever on the engine. The ProAct IV actuator provides up to 27 J (20 ft-lb) of work. The actuators rotate 75 degrees, and they have position feedback.

Figures 1-1 through 1-3 show the control outline drawings, and Figure 1-4 is the plant wiring diagram.

Engine stability and response are set by the controlling device, not by the actuator and driver. Follow the instructions for the controlling device while setting up the engine control system.

Actuator Model	Work Output	Part Number (CW to Max *)	Part Number (CCW to Max *)
ProAct III MS connector	14 J (10 ft-lb)	8405-009	8405-011
ProAct III conduit fitting	14 J (10 ft-lb)	8405-010	8405-012
ProAct IV MS connector	27 J (20 ft-lb)	8405-013	8405-015
ProAct IV conduit fitting	27 J (20 ft-lb)	8405-014	8405-016

\* “CW [CCW] to Max” refers to the direction that the actuator rotates to increase fuel when looking at the rotor.

Table 1-1. ProAct Actuator Specifications

Driver Model	420 mA Cntrl Signal	0200 mA Cntrl Signal	420 mA Cntrl Signal, 420 mA Actuator Pos. Output	0200 mA Cntrl Signal, 420 mA Actuator Pos. Output
Model III MS connector	9905-386	9905-387	9905-459	9905-392
Model III conduit fitting	9905-384	9905-385	N/A	N/A
Model IV MS connector	9905-390	9905-391	9905-461	9905-460
Model IV conduit fitting	9905-388	9905-389	N/A	N/A

Table 1-2. ProAct Driver Configurations

Description	Part Number	Comments
J1 Mating Connector	5416-460	Driver only
J2 Mating Connector	5416-461	Driver and Actuator
J2 Mating Connector (90°)	1631-639	Driver and Actuator
J3 Mating Connector	203-889	Driver only
ProAct III/IV Connector Kit	8923-188	J1, J2 (2), no J3

Table 1-3. ProAct Accessories



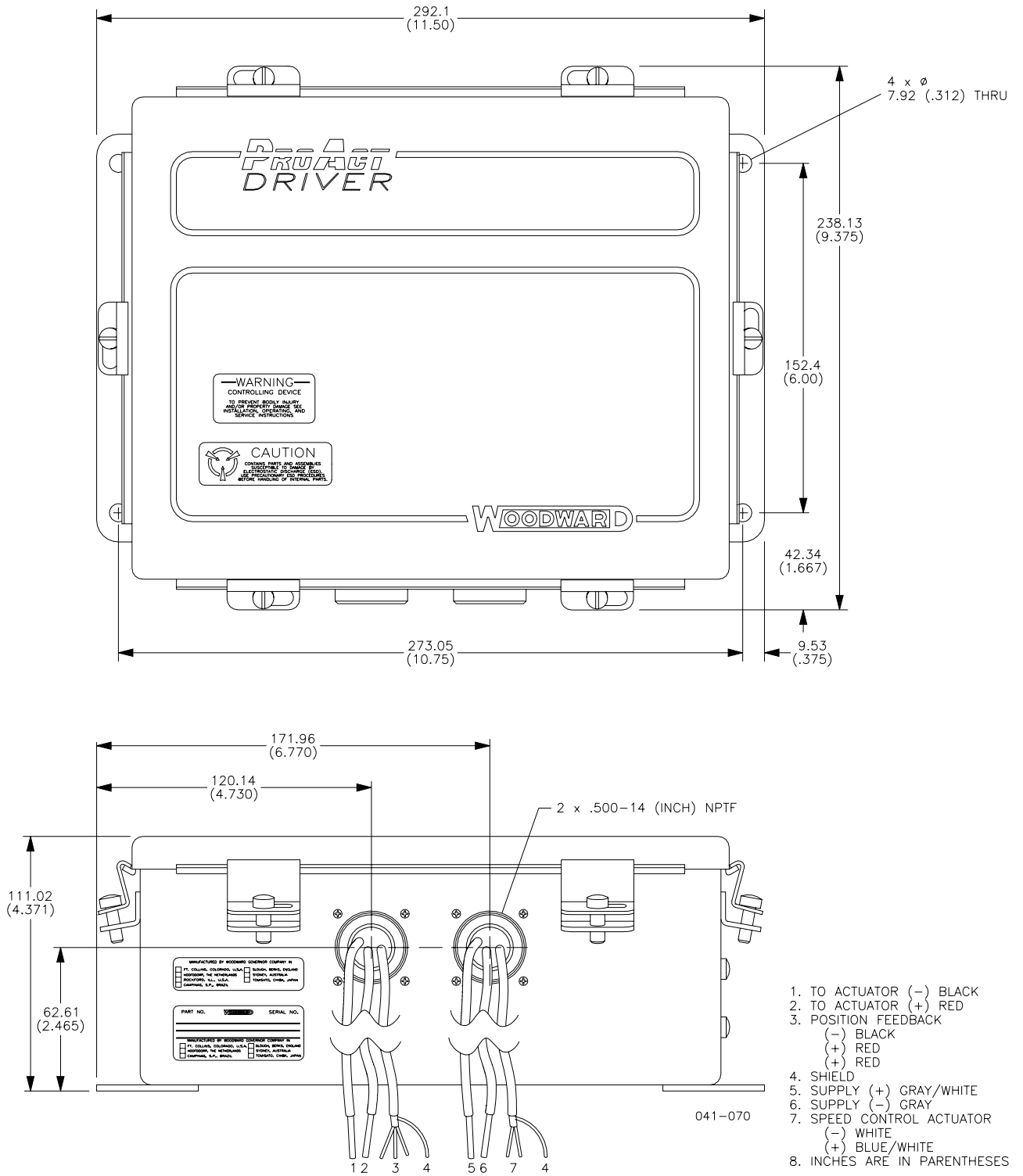

Figure 1-1. ProAct Driver Outline Drawing  
(Conduit version shown; MS connector version has connector plugs)

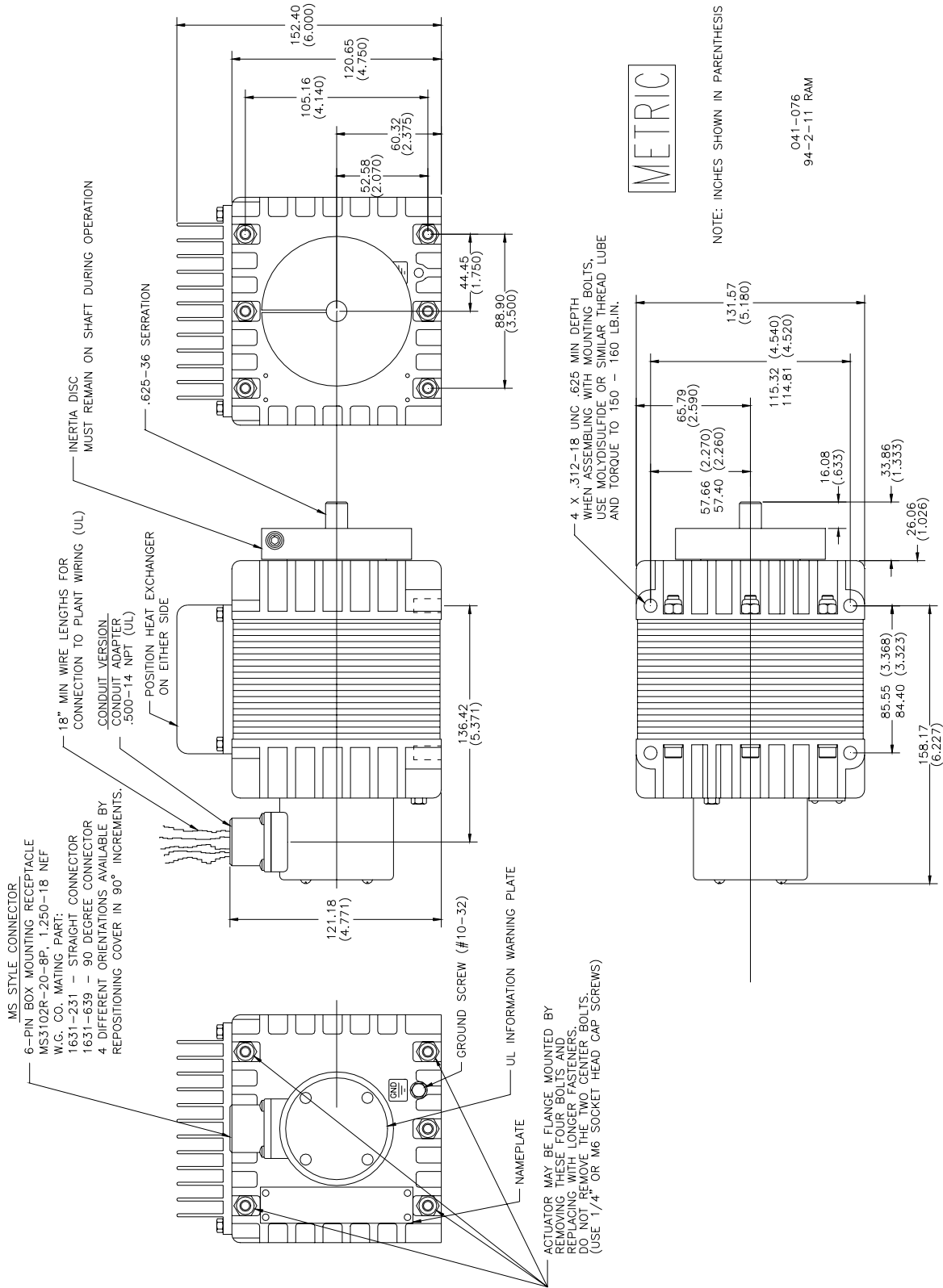

Figure 1-2. ProAct III Actuator Outline Drawing

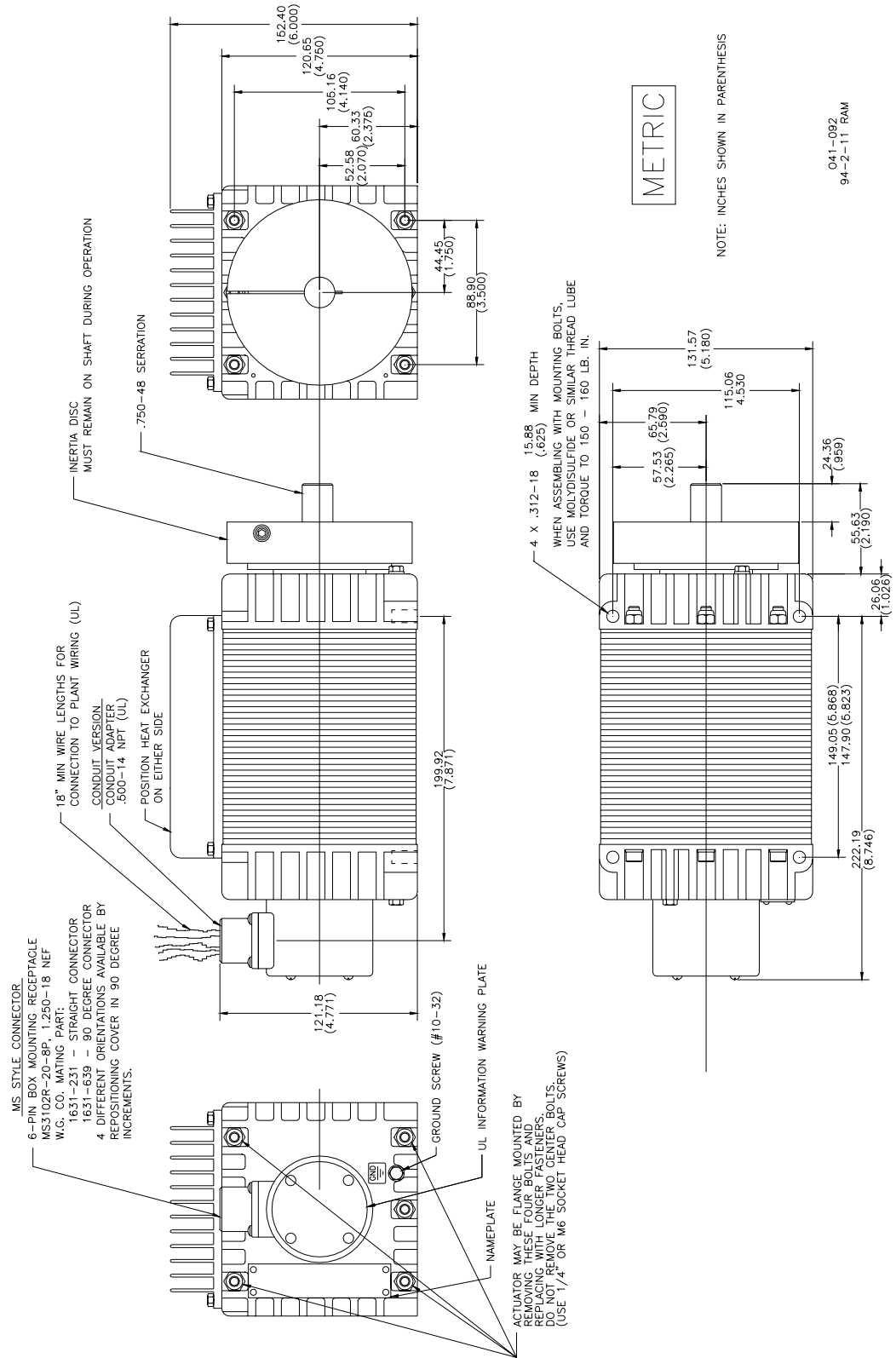
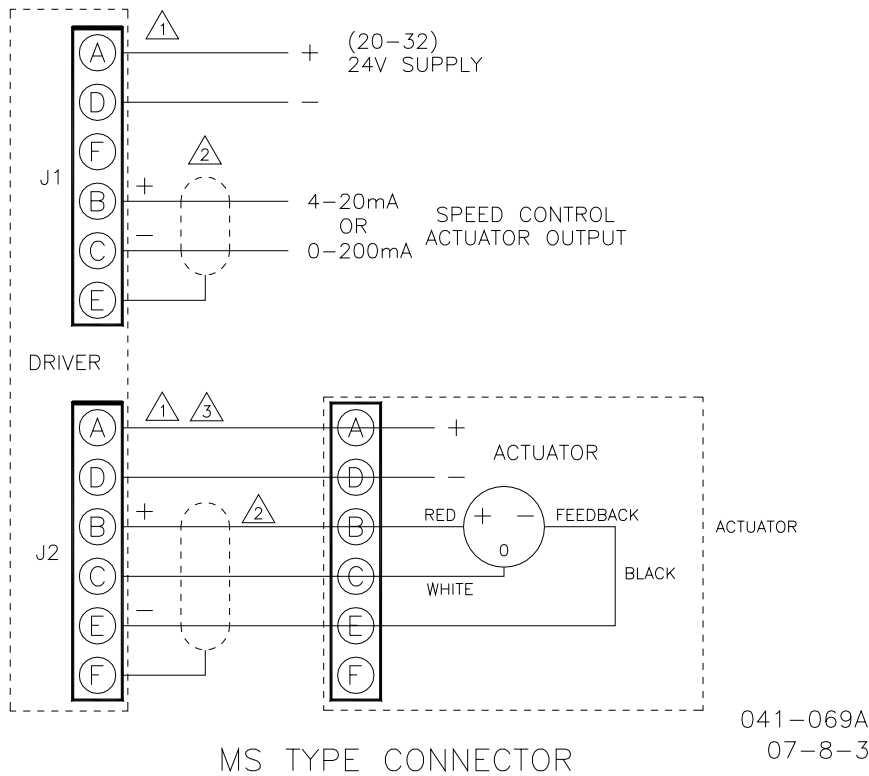
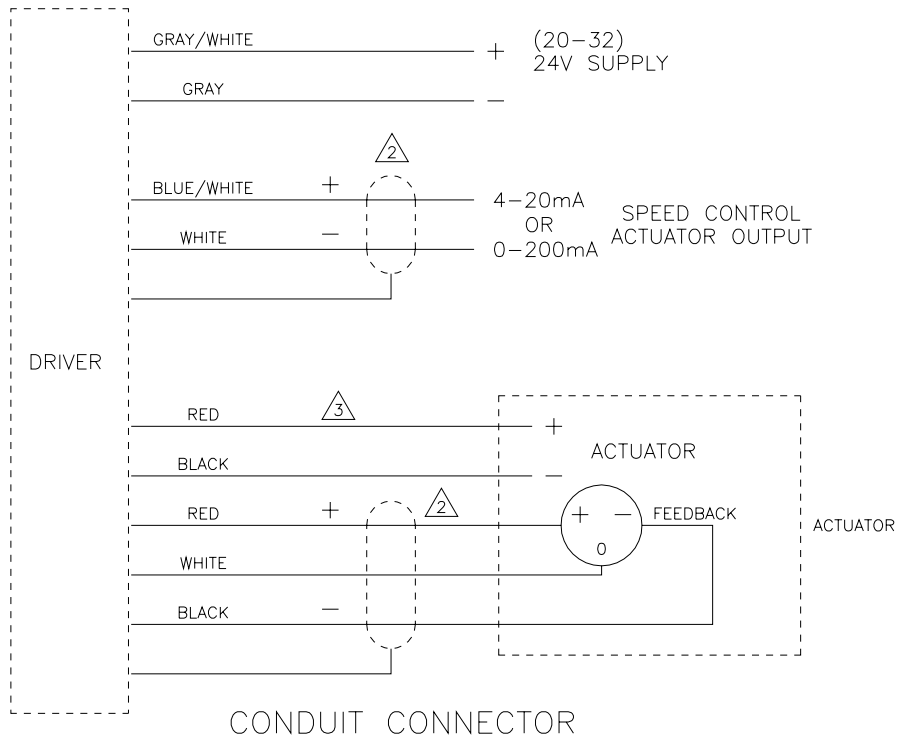

Figure 1-3. ProAct IV Actuator Outline Drawing



NOTE 1—Mating connectors: J1 (5416-460), J2 (5416-461), J3 (203 889).  
 NOTE 2—Shielded wires to be twisted pairs with shield grounded at driver end only.  
 NOTE 3—8, 6, or 4 mm<sup>2</sup> (8, 10, or 12 AWG) stranded wire. Must be as short as possible.  
 Maximum actuator wire lengths are shown on page 12.

Figure 1-4. Plant Wiring Diagram

# Chapter 2. Description of Operation

## Introduction

The ProAct™ control system functions by receiving a current signal from a Woodward electronic governor. The system then sends a pulse width modulated (PWM) current (-20 A to +20 A) signal to the actuator, modified by signals from a position feedback, velocity, and current sensor from the actuator (see Figure 2-1).

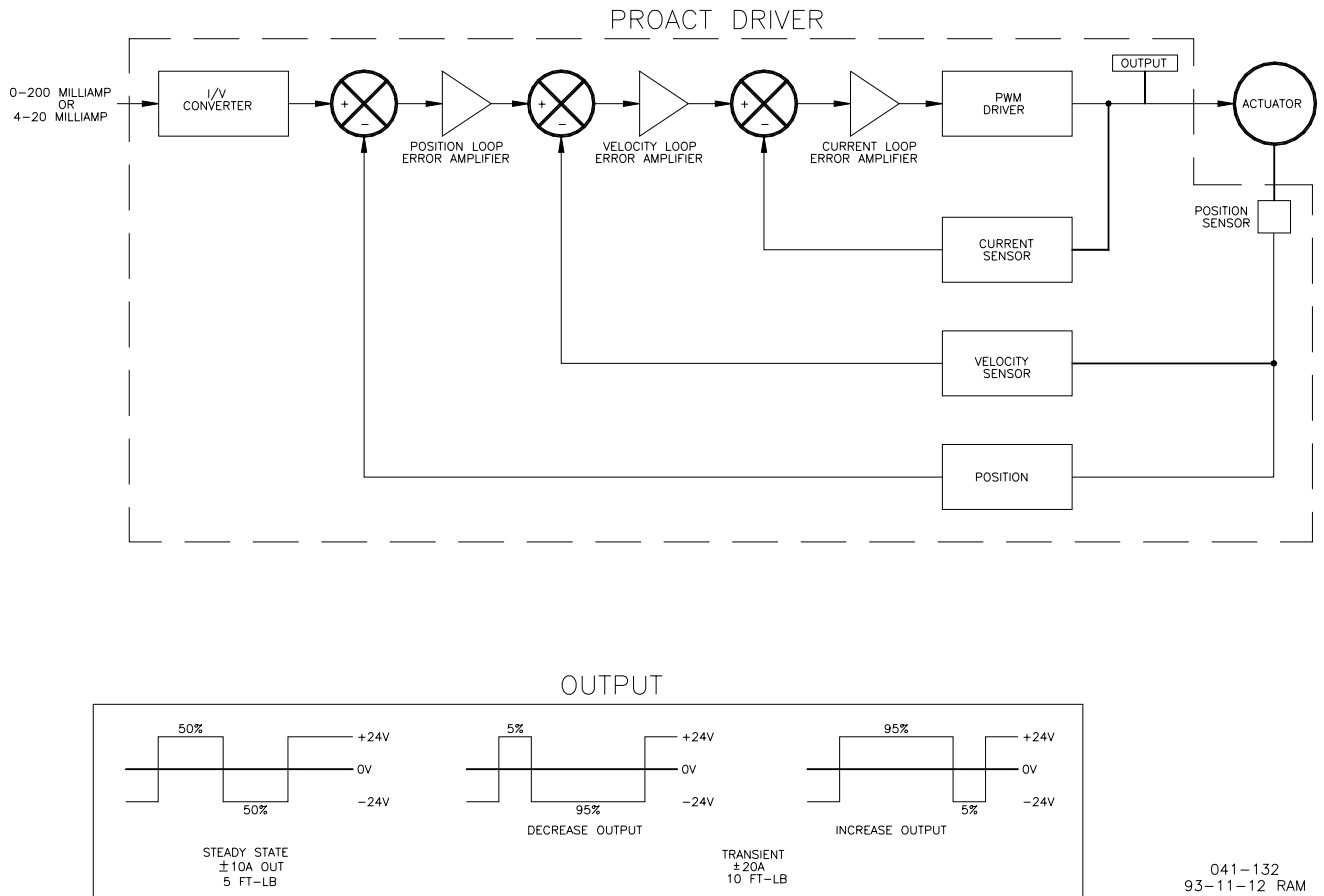

041-132  
93-11-12 RAM

Figure 2-1. ProAct III and IV Functional Block Diagram

## Electronic Circuits

All circuits in the ProAct driver are solid state and are not serviceable in the field. The printed circuit board is manufactured by Woodward to provide maximum tolerance to temperature and vibration.

Three potentiometers, accessible when the cover of the driver box is removed, provide all adjustments to the driver system.

A 25-turn potentiometer (Offset) adjusts the actuator position with a minimum input signal from the speed control.

A 25-turn pot (Span) adjusts how far the actuator travels when the speed control signal varies from minimum to maximum. This pot adjusts the maximum position of the actuator. The Span adjustment range is approximately 40 degrees to 75 degrees.

The Span and Offset adjustments are interrelated. The adjustments may need to be repeated until the desired actuator travel is achieved.

A one-turn pot (ACT. BANDWIDTH) adjusts how quickly the actuator responds to a change in signal from the speed control (bandwidth 2–9 Hz).

## 4–20 mA Output Models

Units which provide a 4–20 mA output proportional to actuator position have two additional 25-turn potentiometers (Position Span and Position Offset). These potentiometers adjust the 4–20 mA output to correspond to minimum and maximum positions of the actuator. The Position Offset adjusts the output at minimum position to be 4 mA. The Position Span adjusts how much the output changes with a given actuator position change and is used to adjust the maximum output current. The adjustments are interrelated and may need to be repeated until the desired output is achieved.

## Actuator Position Signal

The feedback device is located on the closed shaft of the actuator. The device is a rotary transducer which changes resistance proportional to the location of the shaft. The device is a non-contacting unit, thereby eliminating most wear problems. The feedback voltage is approximately 2 Vdc at 0° and 3 Vdc at 75° (measured from 0 to –).

## Actuator

The rotary design of the ProAct actuators gives 75 degrees of shaft rotation to position fuel controls. The actuators apply torque in both directions. Torque is proportional to the current supplied to the actuator by the driver.

The actuator uses sealed bearings, eliminating the need for maintenance. The feedback mechanism attaches to the end of the rotor not being used to control the engine. The device is enclosed in a Ryton housing and is sealed against the elements. Avoid pressure washing the actuator.

An inertia disc is installed on the actuator output shaft. The disc is necessary for stable actuator operation with light, low-friction linkages. Do not remove the disc (see Figures 2-2 and 2-3).

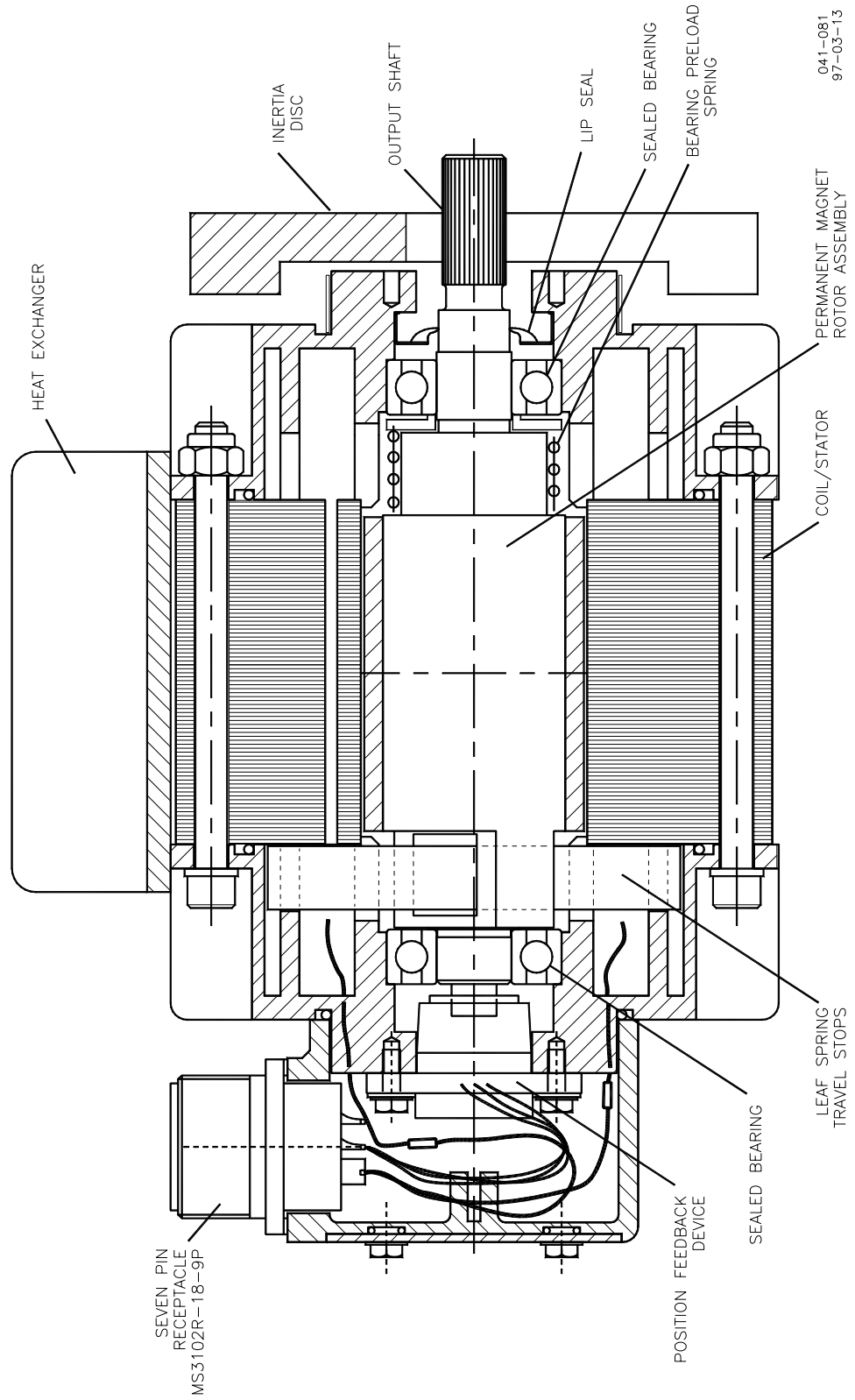

041-081  
97-03-13

Figure 2-2. ProAct III Actuator Cross Section  
(MS connector plug shown, conduit version has conduit connector)

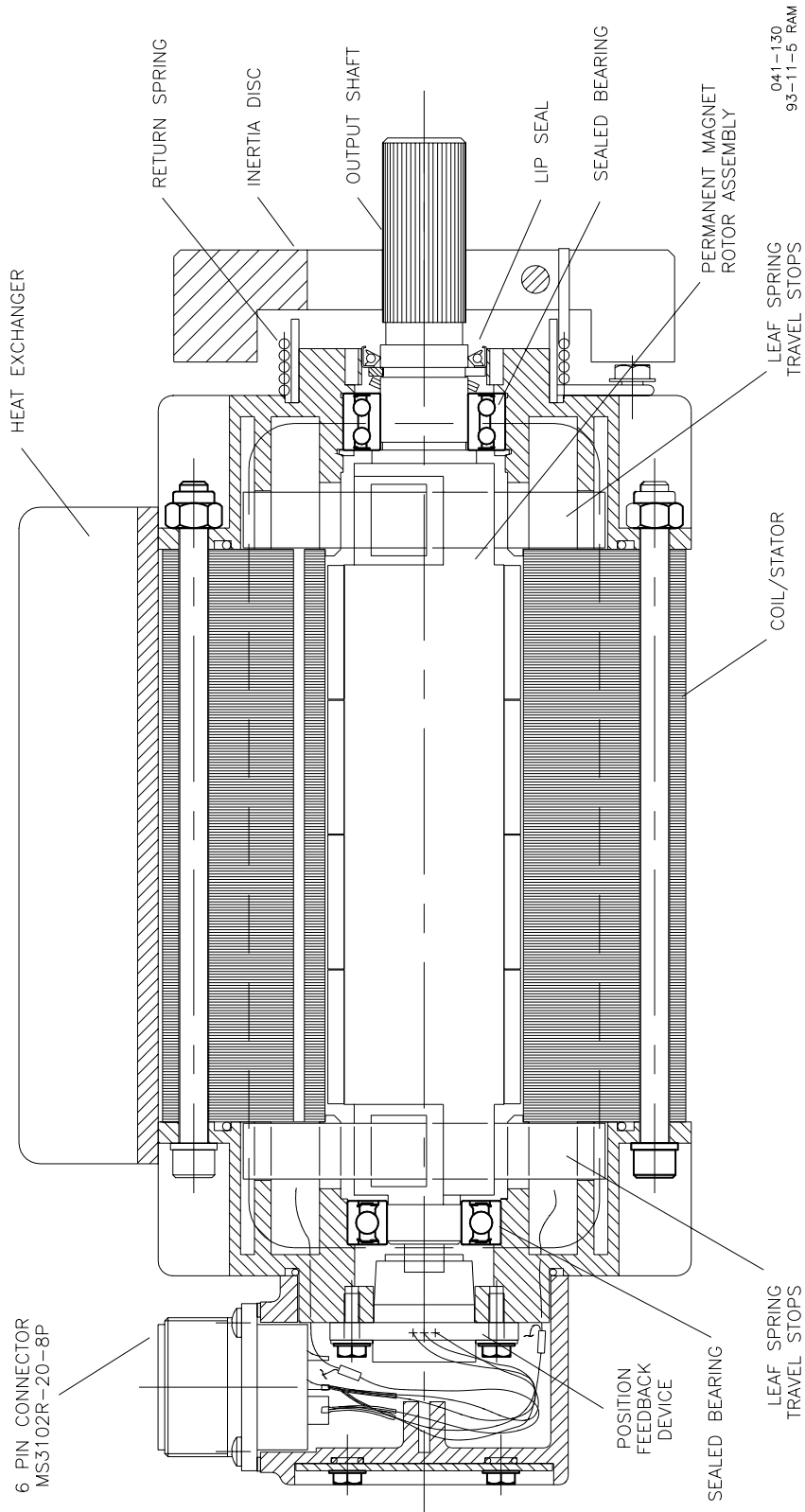

Figure 2-3. ProAct IV Actuator Cross Section  
 (MS connector plug shown, conduit version has conduit connector)



## Chapter 3. Installation

### Driver Installation

#### Unpacking

Be careful when unpacking the electronic driver. Check the driver for signs of damage, such as bent or dented panels, scratches, and loose or broken parts. Notify the shipper and Woodward if damage is found.

#### Mounting

The driver box is designed to operate within a temperature range of  $-40$  to  $+70$  °C ( $-40$  to  $+158$  °F).

Mount the driver in a location with space for adjustment and wiring access. Do not expose the driver to sources of radiant heat such as exhaust manifolds or turbochargers. Mount the driver close enough to the actuator and battery to meet the wire-length requirements (see wiring instructions in this chapter).

The driver will generate some heat, so surfaces must be open to normal air movement. No special ventilation is required. The driver must be bolted to a heat sink of a minimum  $0.4$  m<sup>2</sup> (4 ft<sup>2</sup>) of 3 mm (1/8-inch) mild steel.

Ideally the driver should be mounted flush to the metal side of a control cabinet, protected from the weather and high humidity, and close to the engine being controlled. Do not install the driver directly on the engine. The location should provide protection from high-voltage or high-current devices, or devices which produce electromagnetic interference. After initial adjustments are completed, access to the driver will not be required for normal engine operation.

### Actuator Installation

#### Thermal

The actuators are designed for installation on the engine. The actuators will generate heat, especially when stalled or during other conditions requiring maximum torque output. Maximum operating temperature for either the ProAct™ III or ProAct IV actuator is  $100$  °C ( $212$  °F).

The installer must consider the heat conductivity of the installation bracket, and the operating temperature of the ultimate heat sink to which the bracket will be attached. Generally the heat transfer abilities of aluminum and low-carbon steel are better than those of high-carbon steel or stainless steel.

Uninhibited air flow over the heat-exchanger fins on the side of the actuators will help control possible heat problems. Keep the fins as clean as possible to improve heat transfer. Do NOT paint the fins, since this will reduce the heat transfer efficiency.

If operating temperature is a concern, contact Woodward for more information.

## Fuel Position Stops

**Diesel Stops**—Diesel installations will generally use the fuel system minimum and maximum position stops. Diesel engine racks are normally designed to provide the minimum and maximum stops without binding.

The actuator's stops must not prevent the actuator from driving the fuel linkage to the minimum and maximum positions. The linkage should be designed to use as much actuator travel as possible, without preventing minimum and maximum fuel positions (see Figure 3-1).

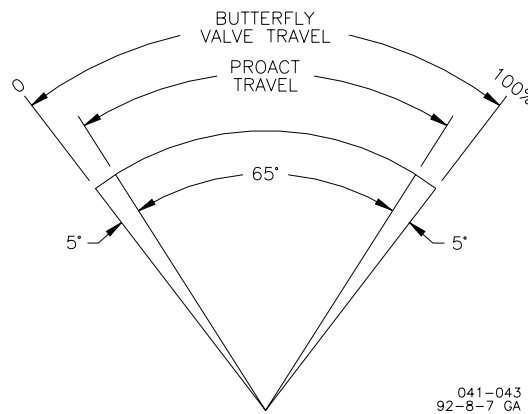
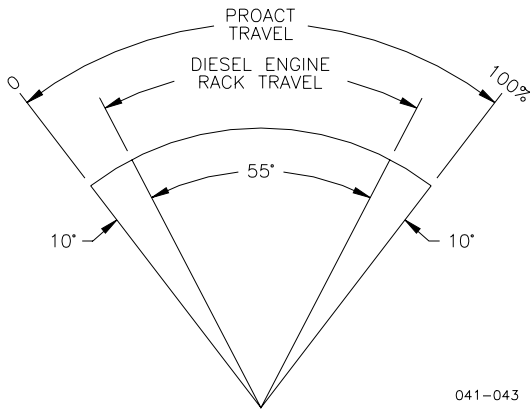

Figure 3-1. Diesel Engine Travel Stops

Figure 3-2. Use ProAct Travel Stops for Carburetors

**Gas Engine Stops**—Butterfly valves in carburetors will often bind if rotated too far toward minimum or maximum. For this reason, the stops in the actuator should be used at both minimum and maximum positions. Note that the stops will allow up to 3 degrees of additional rotation in both directions during impact (see Figure 3-2).

The engine must always shut down when the actuator is at the minimum stop.

## Actuator Bracket

The actuator may be installed on a bracket which attaches to the base with four M8x1.25 (0.312-18) screws with a minimum engagement of 16 mm (0.625 inch). The actuator may be mounted in any attitude. The actuator is weatherproof and resistant to the corrosive effects of water and salt water. Avoid pressure washing near the shaft seals.

The ProAct III actuator weighs 11 kg (25 lbs), and the ProAct IV actuator weighs 19 kg (42 lbs). The bracket and attaching hardware must be designed to hold the weight and to withstand the vibration associated with engine mounting. The bracket must also be designed to provide a heat sink (heat transfer) from the actuator to the engine block. Figure 3-3 provides an illustration of the mounting bracket.

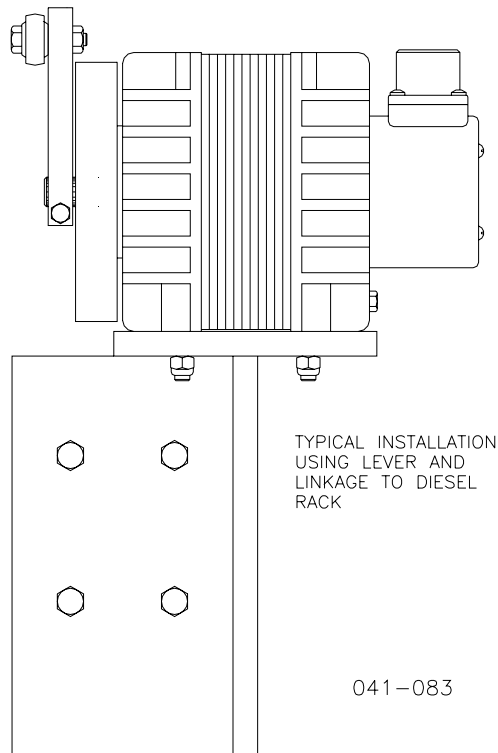

Figure 3-3. Example of Actuator Bracket  
 [When mounting on the bottom of the actuator, torque the attaching bolts to 17 to 18 N·m (150 to 160 lb-in).]

## Linkage

Proper design and installation of the linkage from the actuator to the engine is necessary if the unit is to give good control. Do not remove the inertia disk from the output shaft. It is necessary to achieve steady-state control with low external inertia loads.

Make sure that the actuator has ample work capacity to control the fuel supply under maximum load conditions.

Manually stroke the fuel-control linkage from stop to stop as if the actuator were moving it. The linkage must move freely, without friction, and without backlash. Lubricate or replace worn linkage or fuel control parts as required.

A light loading spring to minimum fuel is included in the actuator. A positive shutdown is necessary in the event of a loss of power to the actuator/driver.



### **CAUTION—MASS MOMENT OF INERTIA**

The actuator's maximum slew rate can place stress on fuel system stops and on the linkage between the actuator and the fuel system. Maximum actuator speed is 900 degrees per second in both the increase and decrease fuel directions. The ProAct III actuator's Mass Moment of Inertia (MMOI) is 0.027 in-lb-sec<sup>2</sup>. The ProAct IV actuator's MMOI is 0.058 in-lb-sec<sup>2</sup>. The fuel system stops must be adequate to absorb this MMOI plus the inertia of the linkage without damage.

ProAct III actuator stops are designed to absorb 1.1 J (10 in-lb) of kinetic energy with 3 degrees overtravel. ProAct IV actuator stops are designed to absorb 2.3 J (20 in-lb) of kinetic energy with 3 degrees of overtravel. If the actuator travel stops are used, the linkage must be designed to allow this 3 degree overrun.

Use good rod-end connectors with as little free play as possible. Select rod ends which will not become loose and which will wear well during the nearly constant movement associated with precise speed control. Low-friction, long-wearing rod ends are available from Woodward.

The link connecting the actuator lever to the fuel-control lever must be short and stiff enough to prevent flexing when the engine is running.

Actuator levers are available from Woodward which allow adjustment of the rod-end location with respect to the center of the actuator shaft. The lever used must have a 0.625-36 serration to fit on the ProAct III actuator or 0.750-48 serration to fit on the ProAct IV actuator.

Adjust the location of the rod end on the lever to achieve the desired rotation of the actuator shaft between minimum and maximum positions. (Use as much of the 75° rotation as possible, at least 60°.) To increase the amount of rotation, move the rod end closer to the actuator shaft or farther away from the shaft controlling fuel flow. To decrease the amount of rotation used, move the rod end farther from the actuator shaft or closer to the shaft controlling fuel flow.

## Electrical Connections

External wiring connections and shielding requirements for a typical control installation are shown in the plant wiring diagram (see Figure 1-4).

Use 8, 6, or 4 mm<sup>2</sup> (8, 10, or 12 AWG) wire throughout the ProAct circuit. The total distance from the battery to the driver and from the driver to the actuator must not exceed the maximum wire length indicated in the following formula: one-half the battery-wire length plus the actuator wire length must be less than or equal to 12.2 m.

For example:

actuator wire length (4 mm <sup>2</sup> )	battery wire length (4 mm <sup>2</sup> )
3.1 m max.	18.2 m max.
6.1 m max.	12.2 m max.
9.1 m max.	6.2 m max.

Actuator wire lengths may be multiplied by 1.6 for 6 mm<sup>2</sup> (10 AWG) wire.  
Actuator wire lengths may be multiplied by 2.5 for 8 mm<sup>2</sup> (8 AWG) wire.

## Shielded Wiring

All shielded cable must be twisted conductor pairs. Do not attempt to tin the braided shield. All signal lines should be shielded to prevent picking up stray signals from adjacent equipment. Connect the shields to the correct pins on the driver connector or wiring. Do not connect shields to the actuator ground. Wire exposed beyond the shield should be as short as possible, not exceeding 50 mm (2 inches). The other end of the shields must be left open and insulated from any other conductor. DO NOT run shielded signal wires along with other wires carrying large currents. See Woodward application note 50532, *EMI Control for Electronic Governing Systems*, for more information.

Where shielded cable is required, cut the cable to the desired length and prepare the cable as instructed below.

1. Strip outer insulation from BOTH ENDS, exposing the braided or spiral wrapped shield. DO NOT CUT THE SHIELD.
2. Using a sharp, pointed tool, carefully spread the strands of the shield.
3. Pull the inner conductor(s) out of the shield. If the shield is the braided type, twist it to prevent fraying.
4. Remove 6 mm (1/4 inch) of insulation from the inner conductors.

The shield must be considered as a separate circuit when wiring the system. The shield must be carried through connectors without interruption.

Installations with severe electromagnetic interference (EMI) may require additional shielding precautions. Contact Woodward for more information.

Failure to provide shielding can produce future conditions which are difficult to diagnose. Proper shielding at the time of installation is required to assure satisfactory operation of the ProAct control system.

## Power Supply

Power supply output must be low impedance (for example, directly from batteries).

Run an insulated wire directly from the positive (+) battery terminal and negative (-) battery terminal to the correct connection on the driver (see Figure 3-4). Run a second insulated wire directly from the negative (-) terminal of the battery to the driver. Neither of these connections needs to be shielded.

Run the power leads directly from the power source to the control. DO NOT POWER OTHER DEVICES WITH LEADS COMMON TO THE CONTROL (see Figure 3-4). For controls with MS type connector (controls and actuators), connect the positive (line) to terminal J1-A and negative (common) to terminal J1- D. For controls with conduit fittings and wires (controls and actuators), connect the positive (line) to the gray/white wire. Connect the negative (-) terminal to the gray wire. If the power source is a battery, be sure the system includes an alternator or other battery-charging device.

When the engine is shut down, the driver powers the actuator into the minimum stop. If the battery charging system is off when the engine is shut down, this will cause the battery to be drained. In this case, the power to the ProAct must be turned off with a switch or relay. Any such switch or relay must be interlocking to prevent starting the engine when power to the actuator is shut off.



### **WARNING—OVERSPEED**

Do not remove power from the driver for normal shutdown procedures. All actuator position commands should come from the control unit, through the driver, to the actuator. Engine overspeed is possible if power is removed from the driver while the engine is running.



### **CAUTION—GROUND LOOPS**

To prevent possible damage to the control, or poor control performance resulting from ground loop problems, follow these instructions.

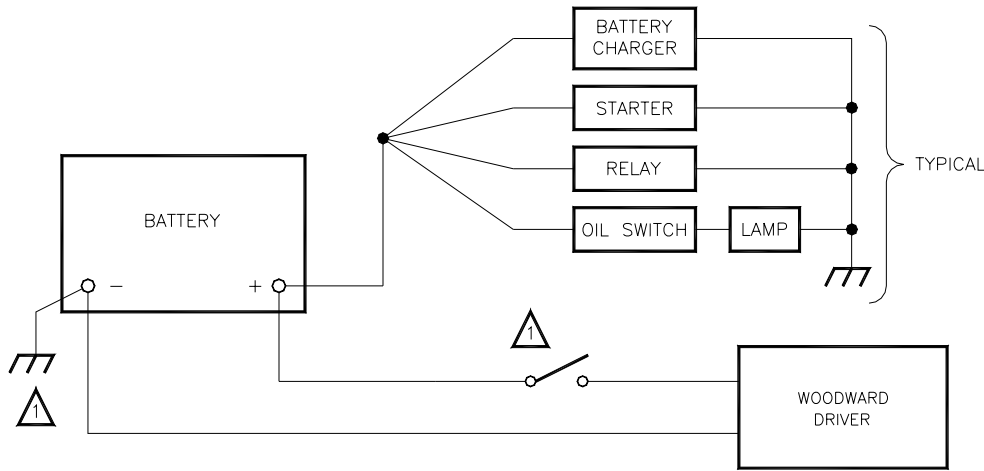

RIGHT

NOTE:

 A NEGATIVE GROUND SYSTEM IS SHOWN. IF A POSITIVE GROUND SYSTEM IS USED, THE SWITCH AND FUSE MUST BE LOCATED IN SERIES WITH BATTERY (-) AND TERMINAL (2) ON THE WOODWARD CONTROL. THE POSITIVE TERMINAL BECOMES CHASSIS GROUND.

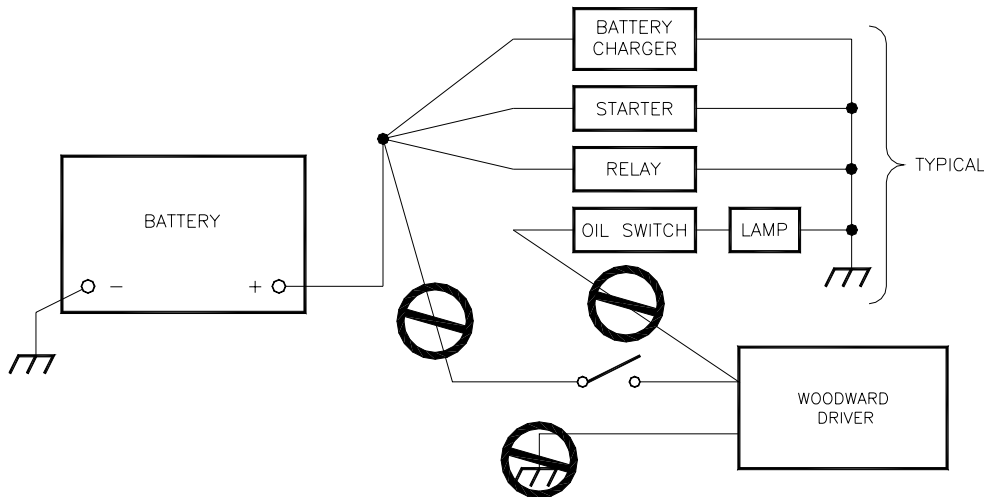

WRONG

041-080  
93-1-4 RAM

Figure 3-4. Wiring to Power Supply

### Driver Adjustments

It is important to set up the ProAct driver in the order that follows. See Figure 3-5 for the location of potentiometers on the driver box.



#### **CAUTION—ELECTROSTATIC DISCHARGE**

**Always hold onto the side of the control box with one hand while making an adjustment with the other hand. This prevents possible static damage to parts.**

**Use an insulated screwdriver to make adjustments. Extensive damage is possible if the high voltages present inside the box are shorted to elements on the board.**

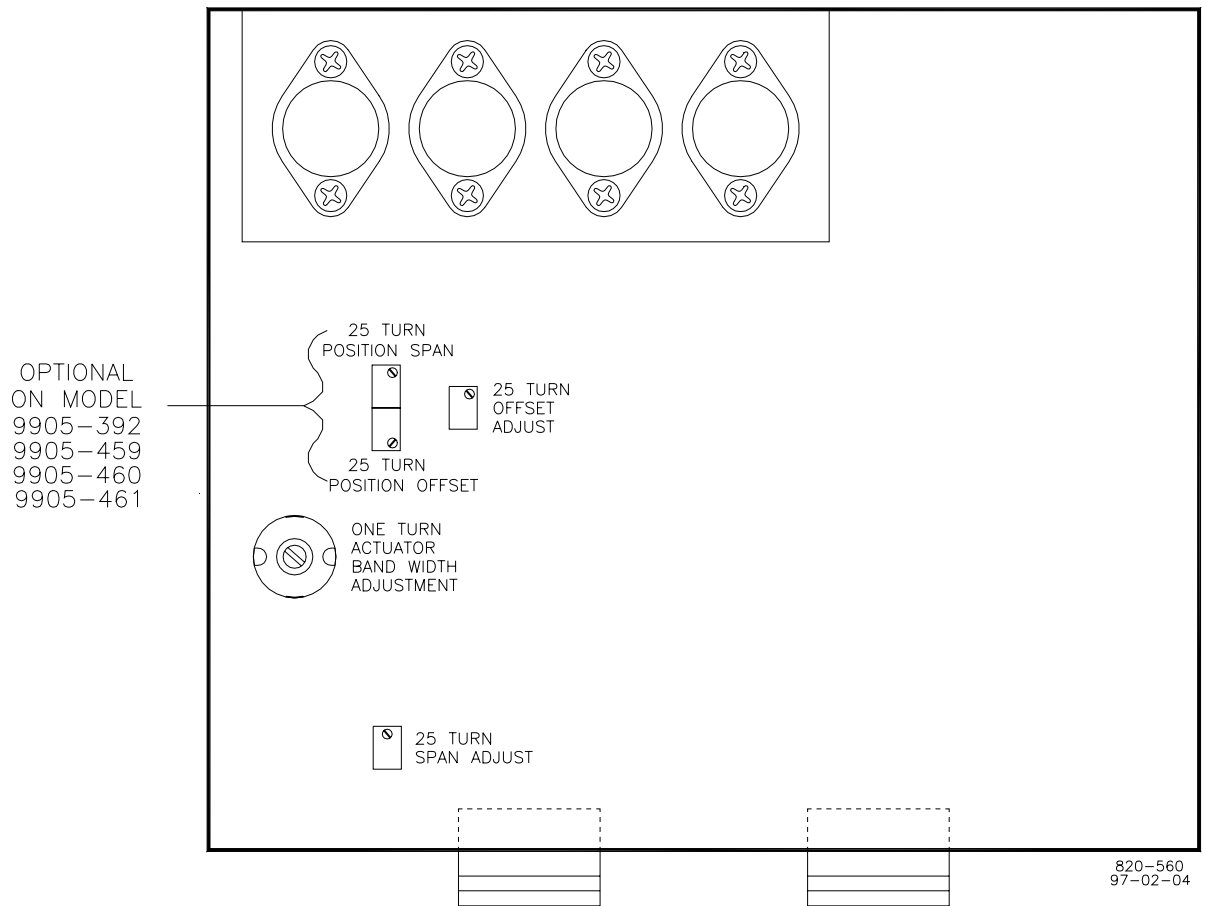

Figure 3-5. ProAct Driver Adjustment Locations

## Actuator Travel

The driver's span and offset adjustments normally don't need to be changed unless you experience difficulty getting the actuator to travel full stroke. The following graphs define the relationship between command signal (0–200 mA or 4–20 mA) and actuator position. If the characteristic falls outside of the tolerance limits, adjust span and offset as required with the goal to get the characteristic midway between the tolerance limits.

To set up the driver and actuator, power up the system with the actuator disconnected from the linkage but with the inertia disk in place. **DO NOT START THE ENGINE AT THIS TIME.**

Vary the current into the mA input to the driver and observe actuator angle. Adjust span and offset to achieve the desired relationship (see Figure 3-6). Failure to make this adjustment correctly may result in the inability to shut off fuel or the inability to reach full fuel position. After this adjustment is made, re-install linkage, coupling, etc., to the engine.

This procedure must be repeated whenever the actuator or driver is changed. The Offset and Range pots are both located on the printed circuit board inside the driver box. The Offset and Range pots are each 25-turn. Both turn clockwise to increase the position of the actuator output for a given input to the driver. See Chapter 2 for the adjustment procedure.

The actuator position feedback sensor is factory set and should not be adjusted.

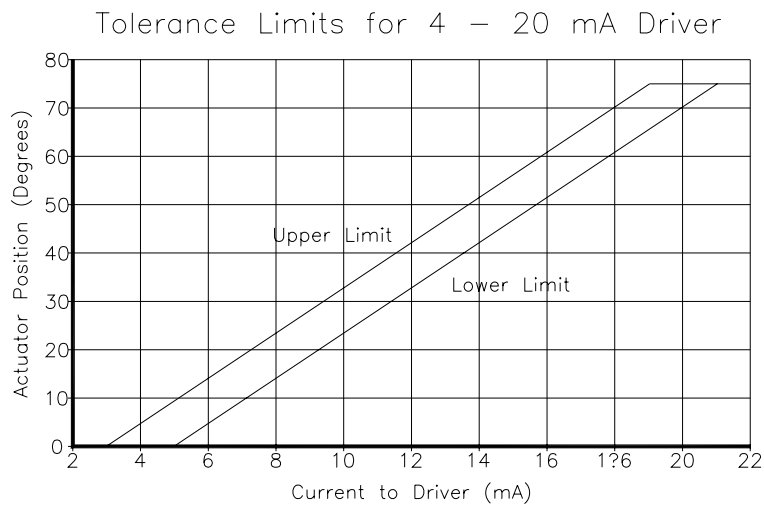
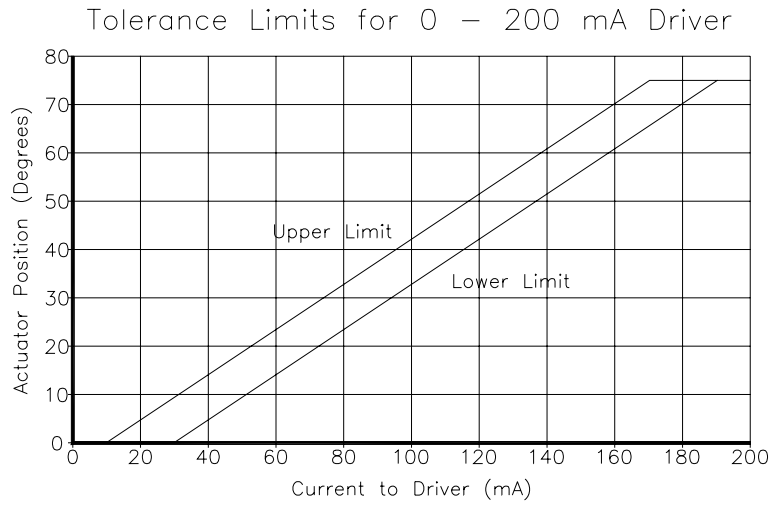

041-131  
93-11-11 RAM

Figure 3-6. Tolerance Limits in Driver Setup



# Chapter 4. Troubleshooting

## Introduction

Improper engine operation is often the result of factors other than governor operation. This chapter gives tips about engine problems which can resemble governor problems. Make sure the engine is operating correctly before making any changes in the governor.

Attempting to correct engine or load problems with untimely governor adjustment can make problems worse.

If possible, isolate the governor from the engine to determine if the problem is with the governor and not with the engine or the load on the engine.

Governor faults are usually caused by problems in the installation or the linkage between the actuator and the engine. Carefully review all the wiring connections, the power supply, and the linkage before making any adjustments to the actuator or driver. Always check the fuel-control linkage from stop to stop as if the actuator were moving it. The linkage must move freely without friction and without backlash. Some fuel controls will present problems at particular fuel or rack positions because of a hesitation or binding in the linkage.

Fuel supply and injector conditions can also present problems which resemble governor problems.

On spark-ignited engines, distributor, coil, points, and timing problems can all cause improper operations which may resemble faulty governor control.

## Linkage and Actuator Stroke

Use as much of the 75 degrees of actuator stroke as possible. Carefully follow the guidelines in the Driver Adjustments section of Chapter 3 in making linkage arrangements. Using less than optimum actuator movement will make stability more difficult, and will make the actuator more sensitive to external loading forces and friction.

# Chapter 5.

## Service Options

### Product Service Options

The following factory options are available for servicing Woodward equipment, based on the standard Woodward Product and Service Warranty (5-01-1205) that is in effect at the time the product is purchased from Woodward or the service is performed:

- Replacement/Exchange (24-hour service)
- Flat Rate Repair
- Flat Rate Remanufacture

If you are experiencing problems with installation or unsatisfactory performance of an installed system, the following options are available:

- Consult the troubleshooting guide in the manual.
- Contact Woodward technical assistance (see “How to Contact Woodward” later in this chapter) and discuss your problem. In most cases, your problem can be resolved over the phone. If not, you can select which course of action you wish to pursue based on the available services listed in this section.

### Replacement/Exchange

Replacement/Exchange is a premium program designed for the user who is in need of immediate service. It allows you to request and receive a like-new replacement unit in minimum time (usually within 24 hours of the request), providing a suitable unit is available at the time of the request, thereby minimizing costly downtime. This is also a flat rate structured program and includes the full standard Woodward product warranty (Woodward Product and Service Warranty 5-01-1205).

This option allows you to call in the event of an unexpected outage, or in advance of a scheduled outage, to request a replacement control unit. If the unit is available at the time of the call, it can usually be shipped out within 24 hours. You replace your field control unit with the like-new replacement and return the field unit to the Woodward facility as explained below (see “Returning Equipment for Repair” later in this chapter).

Charges for the Replacement/Exchange service are based on a flat rate plus shipping expenses. You are invoiced the flat rate replacement/exchange charge plus a core charge at the time the replacement unit is shipped. If the core (field unit) is returned to Woodward within 60 days, Woodward will issue a credit for the core charge. [The core charge is the average difference between the flat rate replacement/exchange charge and the current list price of a new unit.]

**Return Shipment Authorization Label.** To ensure prompt receipt of the core, and avoid additional charges, the package must be properly marked. A return authorization label is included with every Replacement/Exchange unit that leaves Woodward. The core should be repackaged and the return authorization label affixed to the outside of the package. Without the authorization label, receipt of the returned core could be delayed and cause additional charges to be applied.

## Flat Rate Repair

Flat Rate Repair is available for the majority of standard products in the field. This program offers you repair service for your products with the advantage of knowing in advance what the cost will be. All repair work carries the standard Woodward service warranty (Woodward Product and Service Warranty 5-01-1205) on replaced parts and labor.

## Flat Rate Remanufacture

Flat Rate Remanufacture is very similar to the Flat Rate Repair option with the exception that the unit will be returned to you in “like-new” condition and carry with it the full standard Woodward product warranty (Woodward Product and Service Warranty 5-01-1205). This option is applicable to mechanical products only.

## Returning Equipment for Repair

If a control (or any part of an electronic control) is to be returned to Woodward for repair, please contact Woodward in advance to obtain a Return Authorization Number. When shipping the item(s), attach a tag with the following information:

- name and location where the control is installed;
- name and phone number of contact person;
- complete Woodward part number(s) and serial number(s);
- description of the problem;
- instructions describing the desired type of repair.



### **CAUTION—ELECTROSTATIC DISCHARGE**

To prevent damage to electronic components caused by improper handling, read and observe the precautions in Woodward manual 82715, *Guide for Handling and Protection of Electronic Controls, Printed Circuit Boards, and Modules*.

## Packing a Control

Use the following materials when returning a complete control:

- protective caps on any connectors;
- antistatic protective bags on all electronic modules;
- packing materials that will not damage the surface of the unit;
- at least 100 mm (4 inches) of tightly packed, industry-approved packing material;
- a packing carton with double walls;
- a strong tape around the outside of the carton for increased strength.

## Return Authorization Number

When returning equipment to Woodward, please telephone and ask for the Customer Service Department [1 (800) 523-2831 in North America or +1 (970) 482-5811]. They will help expedite the processing of your order through our distributors or local service facility. To expedite the repair process, contact Woodward in advance to obtain a Return Authorization Number, and arrange for issue of a purchase order for the item(s) to be repaired. No work can be started until a purchase order is received.



### NOTE

We highly recommend that you make arrangement in advance for return shipments. Contact a Woodward customer service representative at 1 (800) 523-2831 in North America or +1 (970) 482-5811 for instructions and for a Return Authorization Number.

## Replacement Parts

When ordering replacement parts for controls, include the following information:

- the part number(s) (XXXX-XXXX) that is on the enclosure nameplate;
- the unit serial number, which is also on the nameplate.

## How to Contact Woodward

In North America use the following address when shipping or corresponding:

Woodward Governor Company  
PO Box 1519  
1000 East Drake Rd  
Fort Collins CO 80522-1519, USA

Telephone—+1 (970) 482-5811 (24 hours a day)  
Toll-free Phone (in North America)—1 (800) 523-2831  
Fax—+1 (970) 498-3058

For assistance outside North America, call one of the following international Woodward facilities to obtain the address and phone number of the facility nearest your location where you will be able to get information and service.

<u>Facility</u>	<u>Phone Number</u>
Brazil	+55 (19) 3708 4800
India	+91 (129) 4097100
Japan	+81 (476) 93-4661
The Netherlands	+31 (23) 5661111

You can also contact the Woodward Customer Service Department or consult our worldwide directory on Woodward's website ([www.woodward.com](http://www.woodward.com)) for the name of your nearest Woodward distributor or service facility.

## Engineering Services

Woodward Industrial Controls Engineering Services offers the following after-sales support for Woodward products. For these services, you can contact us by telephone, by email, or through the Woodward website.

- Technical Support
- Product Training
- Field Service

Contact information:

Telephone—+1 (970) 482-5811

Toll-free Phone (in North America)—1 (800) 523-2831

Email—[icinfo@woodward.com](mailto:icinfo@woodward.com)

Website—[www.woodward.com](http://www.woodward.com)

**Technical Support** is available through our many worldwide locations or our authorized distributors, depending upon the product. This service can assist you with technical questions or problem solving during normal business hours. Emergency assistance is also available during non-business hours by phoning our toll-free number and stating the urgency of your problem. For technical support, please contact us via telephone, email us, or use our website and reference **Customer Services** and then **Technical Support**.

**Product Training** is available at many of our worldwide locations (standard classes). We also offer customized classes, which can be tailored to your needs and can be held at one of our locations or at your site. This training, conducted by experienced personnel, will assure that you will be able to maintain system reliability and availability. For information concerning training, please contact us via telephone, email us, or use our website and reference **Customer Services** and then **Product Training**.

**Field Service** engineering on-site support is available, depending on the product and location, from one of our many worldwide locations or from one of our authorized distributors. The field engineers are experienced both on Woodward products as well as on much of the non-Woodward equipment with which our products interface. For field service engineering assistance, please contact us via telephone, email us, or use our website and reference **Customer Services** and then **Technical Support**.

## Technical Assistance

If you need to telephone for technical assistance, you will need to provide the following information. Please write it down here before phoning:

### General

Your Name \_\_\_\_\_

Site Location \_\_\_\_\_

Phone Number \_\_\_\_\_

Fax Number \_\_\_\_\_

### Prime Mover Information

Engine/Turbine Model Number \_\_\_\_\_

Manufacturer \_\_\_\_\_

Number of Cylinders (if applicable) \_\_\_\_\_

Type of Fuel (gas, gaseous, steam, etc) \_\_\_\_\_

Rating \_\_\_\_\_

Application \_\_\_\_\_

### Control/Governor Information

Please list all Woodward governors, actuators, and electronic controls in your system:

Woodward Part Number and Revision Letter

Control Description or Governor Type

Serial Number

Woodward Part Number and Revision Letter

Control Description or Governor Type

Serial Number

Woodward Part Number and Revision Letter

Control Description or Governor Type

Serial Number

*If you have an electronic or programmable control, please have the adjustment setting positions or the menu settings written down and with you at the time of the call.*

# ProAct III/IV Actuator/Driver Specifications

## Driver Part Numbers

9905-384	Model III (conduit), 4–20 mA input
9905-385	Model III (conduit), 0–200 mA input
9905-386	Model III (MS connector), 4–20 mA input
9905-387	Model III (MS connector), 0–200 mA input
9905-388	Model IV (conduit), 4–20 mA input
9905-389	Model IV (conduit), 0–200 mA input
9905-390	Model IV (MS connector), 4–20 mA input
9905-391	Model IV (MS connector), 0–200 mA input
9905-392*	Model III (MS connector), 0–200 mA input
9905-459*	Model III (MS connector), 4–20 mA input
9905-460*	Model IV (MS connector), 0–200 mA input
9905-461*	Model IV (MS connector), 4–20 mA input

\*—These four models have an additional 4-20 mA output which is proportional to actuator position.

## Actuator Part Numbers

8405-009	ProAct III (MS connector), CW to max.
8405-010	ProAct III (conduit), CW to max.
8405-011	ProAct III (MS connector), CCW to max.
8405-012	ProAct III (conduit), CCW to max.
8405-013	ProAct IV (MS connector), CW to max.
8405-014	ProAct IV (conduit), CW to max.
8405-015	ProAct IV (MS connector), CCW to max.
8405-016	ProAct IV (conduit), CCW to max.

## Driver Box

Operating Temperature Range	–40 to +70 °C (–40 to +158 °F)
Storage Temperature Range	–55 to +105 °C (–67 to +221 °F)
Humidity	95% at 38 °C US MIL-STD-810C, Method 507.1, Procedure II SAE J1211, Paragraph 4.2.3
Shock	US MIL-STD-810C, Method 516.2, Proc. III
Power Supply	20 to 32 Vdc (24 Vdc nominal)
Current Requirements	10 A sustained 20 A available for two seconds

## Actuator

Operating Temperature Range	–40 to +100 °C (–40 to +212 °F)
Storage Temperature Range	–55 to +125 °C (–67 to +257 °F)
Shock	US MIL-STD-810C, Method 516.2, Proc. IV
Vibration	US MIL-STD-810C, Method 514.2, Proc. VIII
Output Shaft	0.625-36 serrated (ProAct III) 0.750-48 serrated (ProAct IV)
Mass Moment of Inertia	ProAct III Actuator is 0.027 in-lb-sec <sup>2</sup> ProAct IV Actuator is 0.058 in-lb-sec <sup>2</sup>

**We appreciate your comments about the content of our publications.**

**Send comments to: [icinfo@woodward.com](mailto:icinfo@woodward.com)**

**Please include the manual number from the front cover of this publication.**



**WOODWARD**

PO Box 1519, Fort Collins CO 80522-1519, USA  
1000 East Drake Road, Fort Collins CO 80525, USA  
Phone +1 (970) 482-5811 • Fax +1 (970) 498-3058

**Email and Website—[www.woodward.com](http://www.woodward.com)**

**Woodward has company-owned plants, subsidiaries, and branches,  
as well as authorized distributors and other authorized service and sales facilities throughout the world.**

**Complete address / phone / fax / email information for all locations is available on our website.**