

## **Changing Output Direction on TM-25 and TM-200 Proportional Actuators**

**Application Note 50525 (Revision B)**

## WARNING—DANGER OF DEATH OR PERSONAL INJURY



### WARNING—FOLLOW INSTRUCTIONS

Read this entire manual and all other publications pertaining to the work to be performed before installing, operating, or servicing this equipment. Practice all plant and safety instructions and precautions. Failure to follow instructions can cause personal injury and/or property damage.



### WARNING—OUT-OF-DATE PUBLICATION

This publication may have been revised or updated since this copy was produced. To verify that you have the latest revision, be sure to check the Woodward website:

[www.woodward.com/pubs/current.pdf](http://www.woodward.com/pubs/current.pdf)

The revision level is shown at the bottom of the front cover after the publication number. The latest version of most publications is available at:

[www.woodward.com/publications](http://www.woodward.com/publications)

If your publication is not there, please contact your customer service representative to get the latest copy.



### WARNING—OVERSPEED PROTECTION

The engine, turbine, or other type of prime mover should be equipped with an overspeed shutdown device to protect against runaway or damage to the prime mover with possible personal injury, loss of life, or property damage.

The overspeed shutdown device must be totally independent of the prime mover control system. An overtemperature or overpressure shutdown device may also be needed for safety, as appropriate.



### WARNING—PROPER USE

Any unauthorized modifications to or use of this equipment outside its specified mechanical, electrical, or other operating limits may cause personal injury and/or property damage, including damage to the equipment. Any such unauthorized modifications: (i) constitute "misuse" and/or "negligence" within the meaning of the product warranty thereby excluding warranty coverage for any resulting damage, and (ii) invalidate product certifications or listings.

## CAUTION—POSSIBLE DAMAGE TO EQUIPMENT OR PROPERTY



### CAUTION—BATTERY CHARGING

To prevent damage to a control system that uses an alternator or battery-charging device, make sure the charging device is turned off before disconnecting the battery from the system.



### CAUTION—ELECTROSTATIC DISCHARGE

Electronic controls contain static-sensitive parts. Observe the following precautions to prevent damage to these parts.

- Discharge body static before handling the control (with power to the control turned off, contact a grounded surface and maintain contact while handling the control).
- Avoid all plastic, vinyl, and Styrofoam (except antistatic versions) around printed circuit boards.
- Do not touch the components or conductors on a printed circuit board with your hands or with conductive devices.

## IMPORTANT DEFINITIONS

- A **WARNING** indicates a potentially hazardous situation which, if not avoided, could result in death or serious injury.
- A **CAUTION** indicates a potentially hazardous situation which, if not avoided, could result in damage to equipment or property.
- A **NOTE** provides other helpful information that does not fall under the warning or caution categories.

Woodward Governor Company reserves the right to update any portion of this publication at any time. Information provided by Woodward Governor Company is believed to be correct and reliable. However, no responsibility is assumed by Woodward Governor Company unless otherwise expressly undertaken.

© Woodward 1987  
All Rights Reserved

# Changing Output Direction on TM-25 and TM-200 Proportional Actuators

## Introduction

The output direction of TM-25 and TM-200 actuators may be changed in the field by competent repair personnel. Test equipment which will allow operation of the actuator from minimum to maximum stroke without controlling the fuel valve will be required after making the change.

Extend and retract TM actuators are identical except for the feedback and trim springs which control the position of the torque-motor flapper. Although the springs used in the different actuators vary in scale, they do not vary extensively in appearance. It is important to keep the springs separate and well labeled.

## Models

Actuator models 9904-064 and 9904-060 that extend on increased control signal are fitted with feedback-spring assembly 3018-287 and trim spring 1524-325 to convert them into a 9904-077 or 9904-061 actuator which retracts on increased electrical control signal.

Actuator models 9904-077 and 9904-061 that retract on increased control signal are fitted with feedback spring assembly 3018-283 and trim spring 1524-539 to convert them into a 9905-064 or 9904-060 actuators which extend on increased electrical control signal.

Actuator Part Number	Direction of Output on Increased Fuel Signal	Feedback Spring	Trim Spring
9905-064 (TM-200)	Extend	3018-283	1524-539
9904-060 (TM-25)	Extend	3018-283	1524-539
9904-077 (TM-200)	Retract	3018-287	1524-325
9904-061 (TM-25)	Retract	3018-287	1524-325

The feedback spring assembly includes a spring and a spring seat which is epoxied to the feedback spring.

## Procedure

The following step-by-step procedure is provided to accomplish the change in output direction in the field. After the change is accomplished it will be necessary to install the actuator on a test device so that the amount of servo movement can be adjusted.

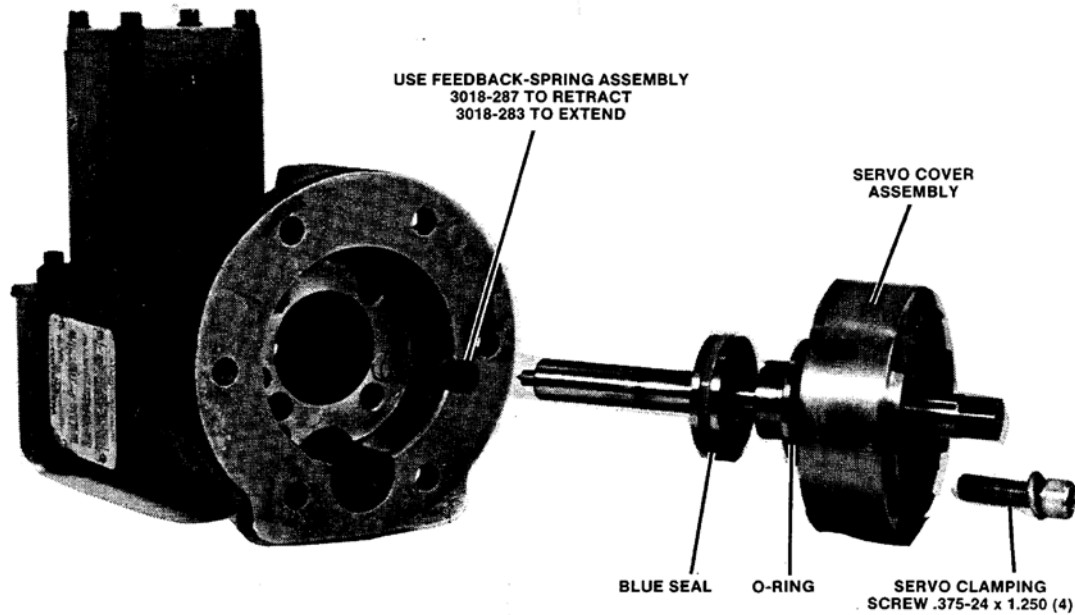

Figure 1. Actuator Body with Servo Piston Removed

1. Place the actuator on a clean workbench.
2. Remove the four 0.375-24 x 1.125 servo clamping screws from the output shaft end of the actuator. (The rod end may be left on the output shaft, if desired.)
3. Remove the servo and the servo-cover assembly from the actuator body by pulling in a straight line. Take care not to damage the O-ring on the cover assembly.
4. Remove the feedback spring assembly (spring with attached spring seat).
5. **Retract**—Replace the spring/spring-seat assembly with Woodward part number 3018-287 if the actuator is being changed to retract on increased fuel signal.

**Extend**—Replace the spring/spring-seat assembly with Woodward part number 3018-283 if the actuator is being changed to extend on increased fuel signal.

The spring seat goes against the end of the servo. The open end of the spring goes into the feedback bore first.

6. Install the servo piston and cover assembly. Take special care not to damage the blue seal on the servo piston. The seal cannot be replaced without special tooling. Use Vaseline on the O-ring to prevent damage as the cover is replaced in the actuator body.
7. Bolt the cover down. Use Led Plate or equivalent on the four stainless steel screws. Torque in an alternating pattern to 16 lb-ft (22 N·m).
8. Remove the cover from the adjustment end of the actuator by removing the three lockwired 0.250-28 cap screws and flat washers.

9. Use a sharp tool to destroy and remove the pressed-in seal in the trim-spring bore.
10. Use a 3/16 Allen wrench to remove the adjustment plug from the trim-spring bore.
11. **Retract**—Replace the trim spring with Woodward part number 1524-225 if the actuator is being changed to retract on increased signal.

**Extend**—Replace the trim spring with Woodward part number 1524-539 if the actuator is being changed to extend on increased signal.

12. Replace the adjustment plug. Take care not to damage the O-ring. Use Vaseline on the O-ring to make installation easier. Turn the adjustment plug in (clockwise) four complete turns.
13. Install the TM actuator on the test facility. Remove the torque motor cover (see Figure 2) and reverse the connections at soldered terminals A and B. Use new shrink tubing at the terminals. Replace the cover and mark the actuator to indicate the change in type.

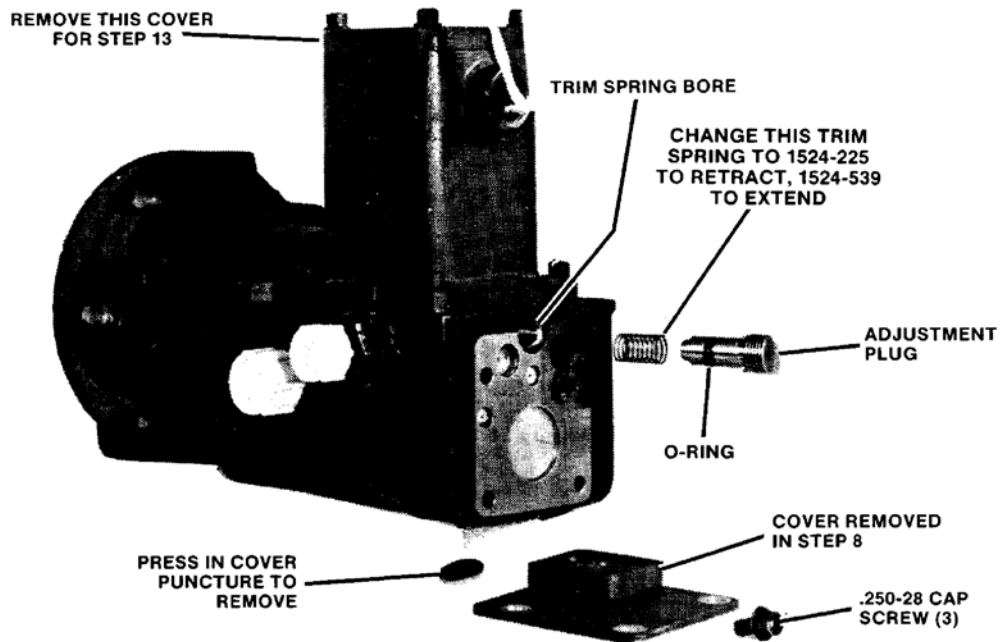

Figure 2. Actuator Body with Adjustment Plug and Trim Spring Removed

14. Calibrate the actuator:

**Extend—**

- a. Turn on the pressure oil supply to the TM actuator. The output shaft should remain at its maximum retraction. If necessary, adjust the plug replaced in step 12 so that there is no movement of the shaft when the pressure oil is turned on.
- b. Set a travel indicator on the output shaft.
- c. Set the input current to 40 mA.
- d. Adjust the plug replaced in step 12 to extend the servo 0.125" (3.18 mm). Turn counterclockwise to increase the amount of travel, or clockwise to decrease the amount of travel.
- e. Set the test current to 200 mA. The output shaft should extend an additional 0.875" (22.22 mm) for a total movement of 1.000 to 1.025 inches (25.40 to 26.04 mm).

**Retract—**

- a. Turn on the pressure oil supply to the TM actuator. Adjust the plug replaced in step 12 so that the output shaft extends 1.000 to 1.025 inches (25.40 to 26.04 mm) from the body.
- b. Set a travel indicator on the output shaft.
- c. Set the input current to 40 mA.
- d. Adjust the plug replaced in step 12 to retract the shaft 0.125" (3.18 mm) with the application of 40 mA. (Turn clockwise to cause the shaft to retract more, or counterclockwise to cause the shaft to retract less.)
- e. Set the test current to 200 mA. The output shaft should retract an additional 0.875" (22.22 mm).

15. Install the new adjustment plug press-in seal.
16. Install the cover with the three screws and flat washers. Use Led Plate on the screws. Lockwire the screws to prevent removal of the cover in the future.
17. Change the part number of the actuator to conform to the new output direction.

When installing the reworked actuator be sure that:

- Linkage is correct to provide complete control of the fuel valve.
- Wiring is correct to provide the desired output movement on increased fuel signal.
- The engine or turbine is equipped with emergency shutdown equipment.



We appreciate your comments about the content of our publications.

Send comments to: [icinfo@woodward.com](mailto:icinfo@woodward.com)

Please include the manual number from the front cover of this publication.



PO Box 1519, Fort Collins CO 80522-1519, USA  
1000 East Drake Road, Fort Collins CO 80525, USA  
Phone +1 (970) 482-5811 • Fax +1 (970) 498-3058

Email and Website—[www.woodward.com](http://www.woodward.com)

Woodward has company-owned plants, subsidiaries, and branches,  
as well as authorized distributors and other authorized service and sales facilities throughout the world.

Complete address / phone / fax / email information for all locations is available on our website.